

INSTALLATION INSTRUCTIONS

SERIES BG450, BG520, BG525, BG600, BT525, AND BT600

BG AND BT WINDOW WALL SYSTEMS

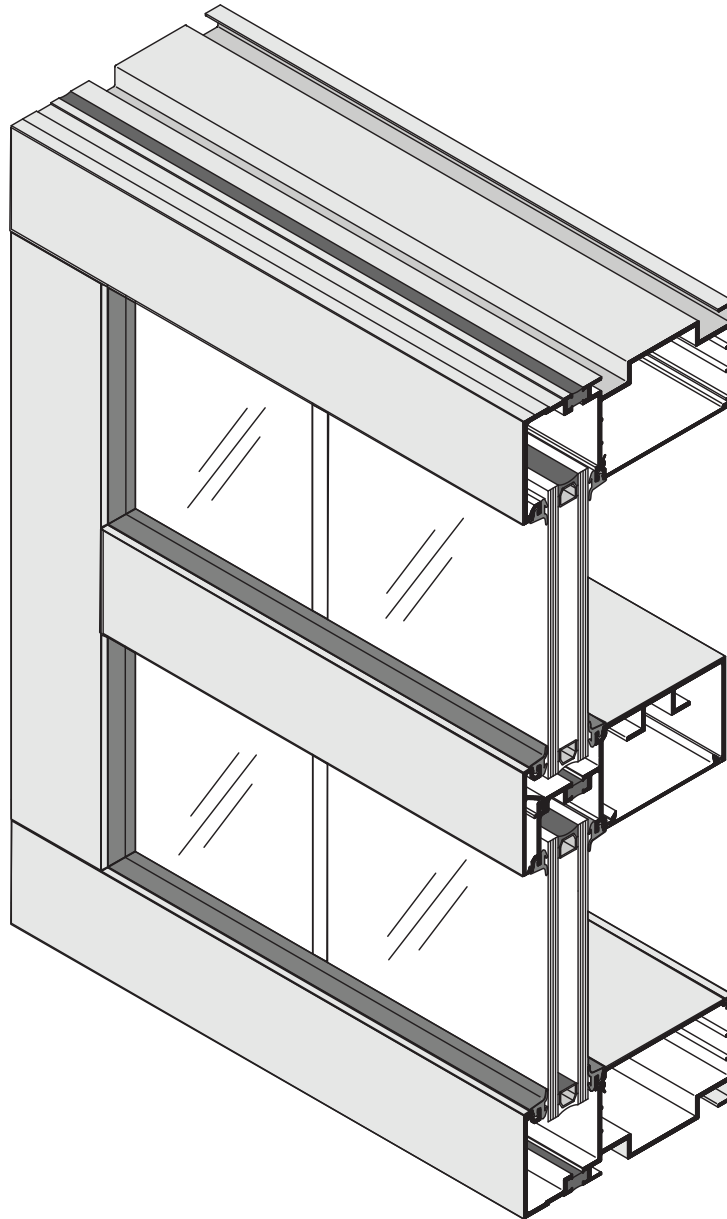

Phone: (800) 262-5151 • Fax: (866) 262-3299
crlaurence.com • usalum.com • crl-arch.com

HANDLING, STORAGE, AND PROTECTION OF ALUMINUM

The following precautions are recommended to protect the material against damage. Following these precautions will help ensure early acceptance of your products and workmanship.

A. HANDLE CAREFULLY.

All aluminum materials at job site must be stored in a safe place, well removed from possible damage by other trades. Cardboard wrapped or paper interleaved materials must be kept dry.

B. CHECK ARRIVING MATERIALS.

Check for quantity counts and keep records of where various materials are stored.

C. KEEP MATERIALS AWAY FROM WATER, MUD, AND SPRAY.

Prevent cement, plaster, or other materials from damaging the finish.

D. PROTECT THE MATERIALS AFTER ERECTION.

Protect erected frame with polyethylene or canvas splatter screen. Cement, plaster, terrazzo, other alkaline solutions, and acid based materials used to clean masonry are harmful to the finish. ***If any of these materials come in contact with the aluminum, immediately remove with water and mild soap.***

The rapidly changing technology within the architectural aluminum products industry demands that U.S. Aluminum reserve the right to revise, discontinue or change any product line, specification or electronic media without prior written notice.

NOTE: Dimensions in parentheses () are millimeters unless otherwise noted.

GENERAL INSTALLATION NOTES

Recommended guidelines for all installations:

1. **REVIEW CONTRACT DOCUMENTS.** Check shop drawings, installation instructions, architectural drawings and shipping lists to become thoroughly familiar with the project. The shop drawings take precedence and include specific details for the project. Note any field verified notes on the shop drawings prior to installing. The installation instructions are of a general nature and cover most conditions.
2. **INSTALLATION.** All materials are to be installed plumb, level, and true.
3. **BENCH MARKS.** All work should start from bench marks and/or column lines as established by the architectural drawings and the general contractor with guaranteed accuracy. Working from these datum points and lines determine:
 - a) The plane of the wall in reference to offset lines provided on each floor.
 - b) The finish floor lines in reference to bench marks on the outer building columns.
 - c) Mullion spacing from both ends of masonry opening to prevent dimensional build-up of daylight opening.
4. **FIELD WELDING.** All field welding must be adequately shielded to avoid any splatter on glass or aluminum. Results will be unsightly and/or structurally unsound. Advise general contractor and other trades accordingly. All field welds of steel anchors must receive touch-up paint (zinc chromate) to avoid rust.
5. **SURROUNDING CONDITIONS.** Make certain that construction which will receive your materials is in accordance with the contract documents. If not, notify the general contractor in writing and resolve differences before proceeding with work.
6. **ISOLATION OF ALUMINUM.** Aluminum to be placed in direct contact with uncured masonry or incompatible materials should be isolated with a heavy coat of zinc chromate or bituminous paint.
7. **SEALANTS.** Sealants must be compatible with all materials with which they have contact with (full or incidental), including other sealant surfaces. It is the sole responsibility of the glass company to consult the sealant manufacturer for recommendations regarding joint size, shelf life, compatibility, cleaning, priming, tooling, adhesion, etc. It is the responsibility of the **Glazing Contractor** to submit a statement from the sealant manufacturer indicating that glass and glazing materials have been tested for compatibility and adhesion with glazing sealants, and interpreting test results relative to material performance, including recommendations for primers and substrate preparation required to obtain adhesion. The chemical compatibility of all glazing materials and framing sealants with each other and with like materials used in glass fabrication must be established. ***This is required on every project.***
8. **FASTENING.** Within the body of these instructions "fastening" means any method of securing one part to another or to adjacent materials. Only those fasteners used within the system are specified in these instructions. Due to the varying perimeter conditions and performance requirements, perimeter and anchor fasteners are not specified in these instructions. For perimeter and anchor fasteners refer to the shop drawings or consult the fastener supplier.
9. **BUILDING CODES.** Due to the diversity in state/provincial, local, and federal laws and codes that govern the design and application of architectural products, it is the responsibility of the individual architect, owner, and installer to assure that products selected for use on projects comply with all the applicable building codes and laws. U. S. Aluminum exercises no control over the use or application of its products, glazing materials, and operating hardware, and assumes no responsibility thereof.
10. **EXPANSION JOINTS.** Expansion joints and perimeter seals shown in these instructions and in the shop drawings are shown at normal size. Actual dimensions may vary due to perimeter conditions and/or difference in metal temperature between the time of fabrication and the time of installation. Gaps between expansion members should be based on temperature at time of installation.
11. **WATER HOSE TEST.** As soon as a representative amount of the wall has been glazed (500 square feet or 46.5 m²) a water hose test should be conducted in accordance with AAMA 502-08 specifications to check the installation. On all jobs the hose test should be repeated every 500 square feet (46.5 m²) during the glazing operation.
12. **COORDINATION WITH OTHER TRADES.** Coordinate with the general contractor any sequence with other trades which offset curtain wall installation (i.e. fire proofing, back-up walls, partitions, ceilings, mechanical ducts, converters, etc.).
13. **CARE AND MAINTENANCE.** Final cleaning of exposed aluminum surfaces should be done in accordance with AAMA 609.1 for anodized aluminum and 610.1 for painted aluminum.
13. **JOB SITE ESSENTIALS.** See pages 23 and 24.

INSTALLATION INSTRUCTIONS

Most details in these instructions show Series BT525 members for 1" (25) glazing. Series BG450, BG520, BT525, and BG600, are similar.

Measure ROUGH OPENING to determine FRAME DIMENSION, allowing 1/4" (6.4) minimum clearance for shimming and caulking around perimeter.

FRAME FABRICATION

1. Cut members to size:

Head and Sill:

FRAME WIDTH

If opening exceeds 24' (7.32 m) in width, splice sleeves must be used at splice joints. See page 17.

Wall jambs:

FRAME HEIGHT MINUS 4-5/8" (117.5) or

FRAME HEIGHT MINUS 4-11/16" (119.1) if optional perimeter face covers are used. See page 20.

Wall jamb inserts and Verticals:

FRAME HEIGHT MINUS 1-5/16" (33.3)

Horizontal members:

D.L.O. = +0" -1/32" (0.8)

Head and Sill fillers:

D.L.O. = +0" -1/32" (0.8)

Horizontal face covers:

FRAME WIDTH MINUS 4-9/16" (115.9) (See page 17 for splice joints) or
FRAME WIDTH MINUS 4-11/16" (119.1) if perimeter covers are used.

Optional Head and Sill face covers:

FRAME WIDTH PLUS 3/16" (4.8)

Face covers extend 3/32" (2.4) past head/sill. If elevation exceeds 15' (4.6m.) in width splice covers at vertical's center line. See page 17.

Optional Wall jamb face covers:

FRAME HEIGHT MINUS 4-11/16" (119.1)

Vertical transition adaptors:

D.L.O. PLUS 1-1/4" (31.8) for intermediate lites. See page 16.

D.L.O. PLUS 1/2" (12.7) for top and bottom lites. See page 16.

D.L.O. for head to sill light.

Horizontal transition adaptors:

D.L.O. MINUS 1/8" (3.2). See page 16.

2. Drill 5/16" (7.9) Weep Holes in sill member, two per glass bay, at quarter points. **See DETAIL A.**

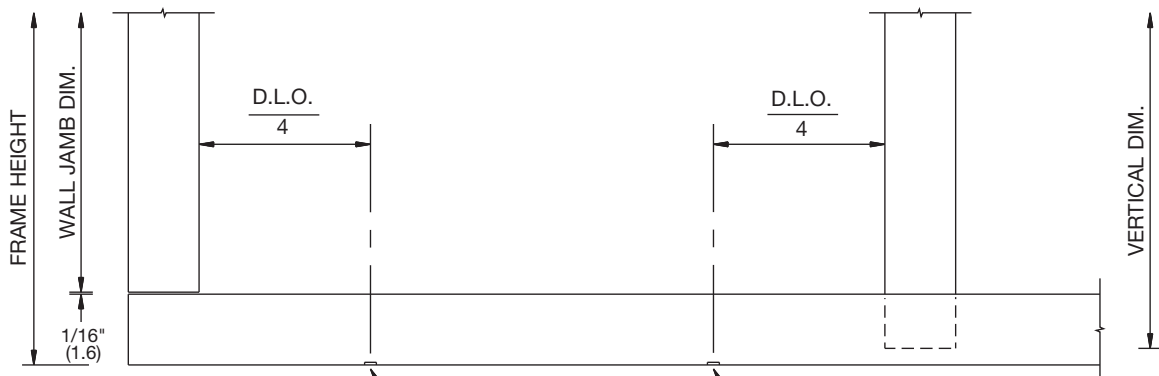

DETAIL A

Drill two 5/16" (7.9) dia. Weep Holes, **DETAIL C** page 05.

SERIES BG450, BG520, BG525, BG600, BT525, AND BT600

3. Attach End Dams to ends of head and sill apply **CRL RTV408 Silicone Sealant** to contact areas. See **DETAIL B**.

NOTE:

Clean all surface prior to applying sealants. See sealant manufacturer requirements. **TYPICAL AT ALL CONDITIONS**

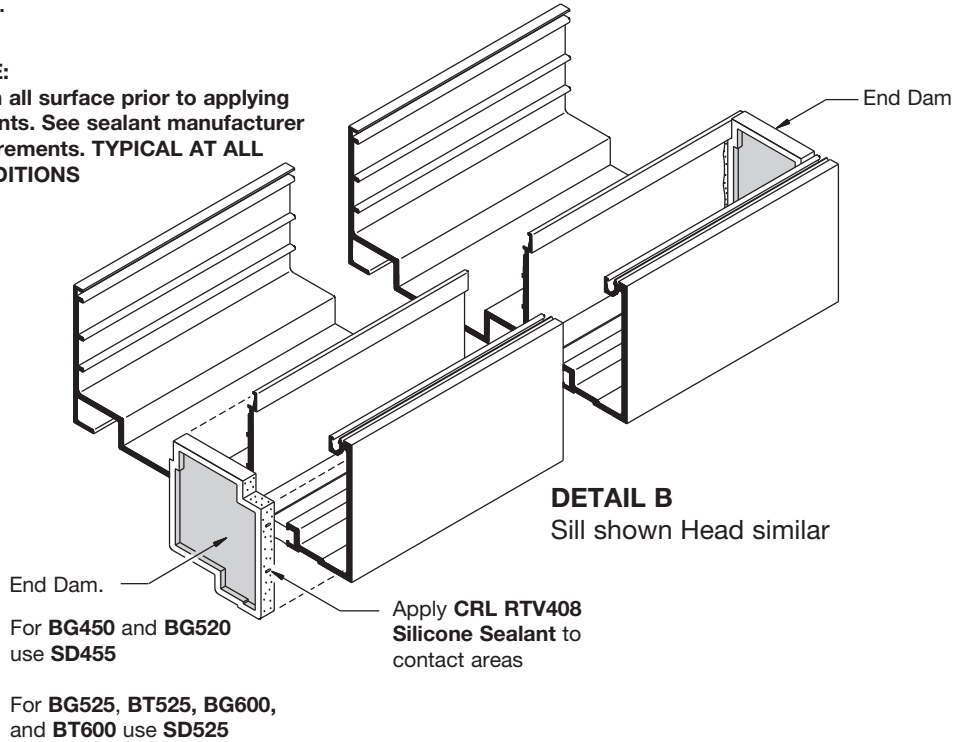

4. Seal around End Dams in sill and head gutters. See **DETAIL C**. (End Dams are required at head to control air infiltration).

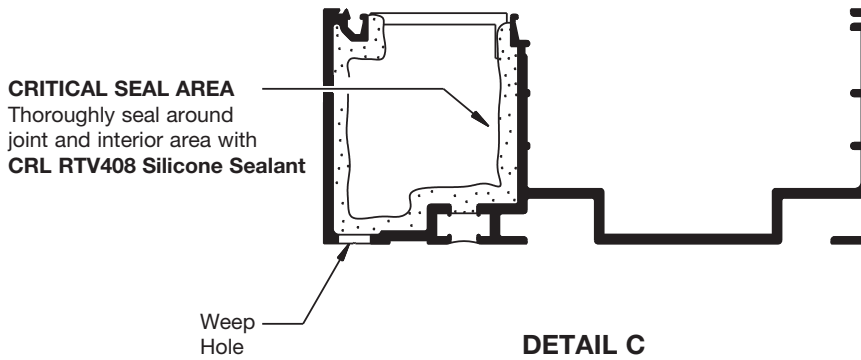

5. Mark on verticals and jamb inserts the location of horizontal members and drill holes for assembly screws. See **DETAIL D**. The use of drill jigs is recommended. See **DETAIL E**.

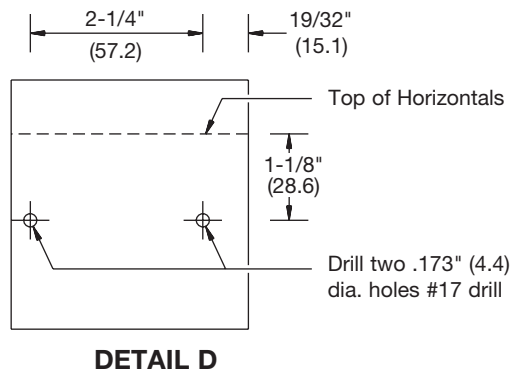

SERIES BG450, BG520, BG525, BG600, BT525, AND BT600

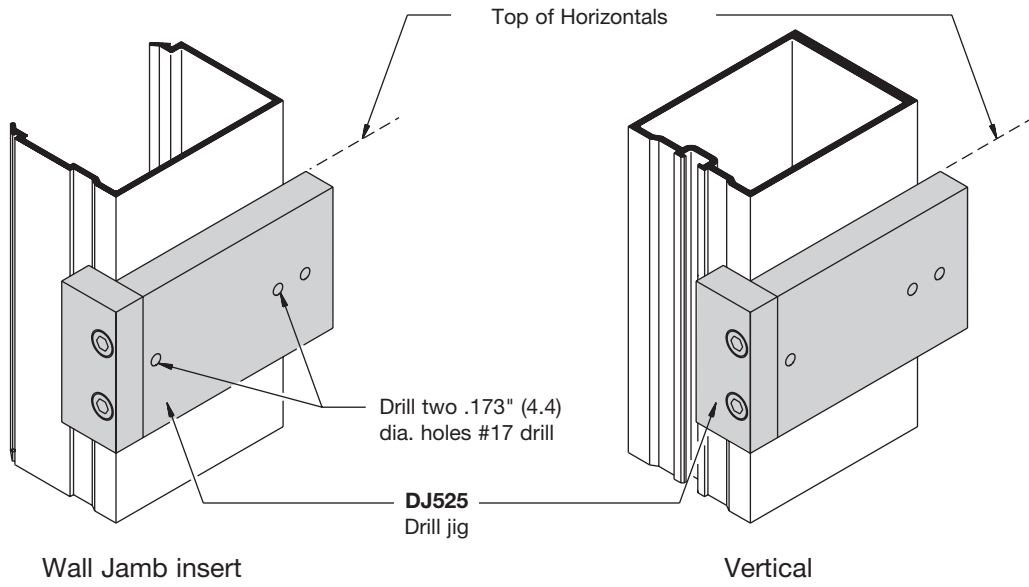

DETAIL E

6. Attach anchor clips to verticals with screws provided. **See DETAIL F.**

NOTE:

Visit our website at crlaurence.com for details about our **Accufab Pro** Cat. No. **ACU24** and **ACU32** Shear Block Positioning System.

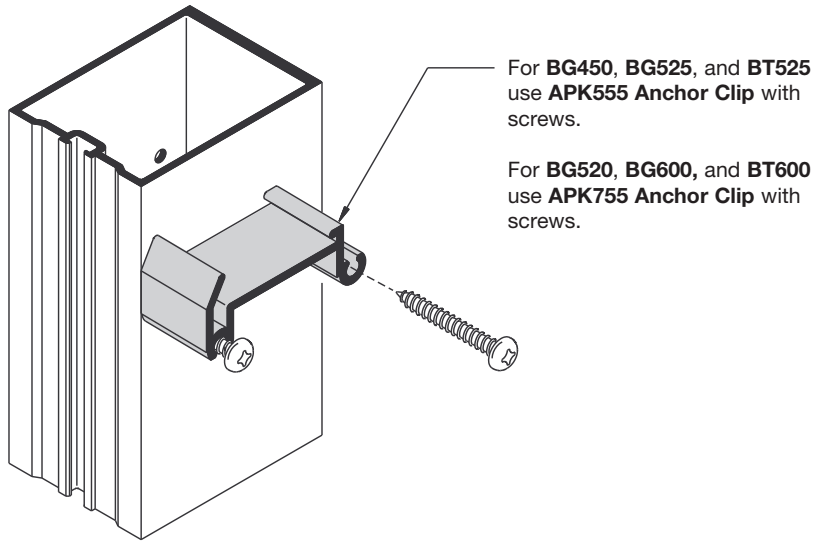

DETAIL F

FRAME INSTALLATION

NOTE: Always check overall dimension every four bays to monitor horizontals cutting tolerances.

1. Set head and sill members in place, plumb and square; shim as required to level and fasten to structure. Locate fasteners 6" (152.4) each side of verticals and 24" (609.6) O.C. or as required. Holes for fasteners should be elongated laterally to allow for thermal movement. **Pin sill to structure at one point only per cut length** (This hole is not elongated). Sill should be shimmed at fasteners locations and under setting blocks and verticals. Splice head and sill members as required. See page 17.

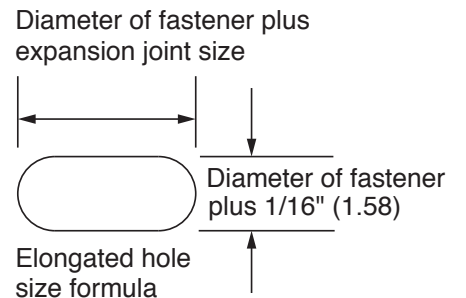

SERIES BG450, BG520, BG525, BG600, BT525, AND BT600

2. Insert Urethane Baffles into sill gutter at Weep Hole locations. (Use silicone to hold them in place if necessary).
See **DETAIL G**.

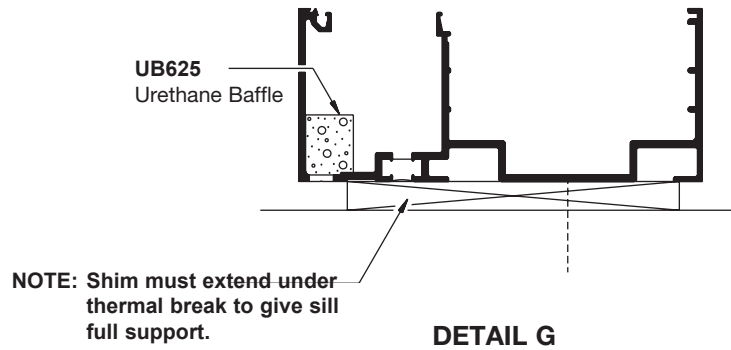

If optional perimeter face covers are being used, see page 20.

3. Install wall jamb plumb and anchor to wall at 24" (609.6) O.C. or as required. Leave a 1/16" (1.6) clearance between jamb and head/sill members. See **DETAIL A** on page 04. Seal joint at face and side with **RTV408 Silicone Sealant**. See **DETAIL H**.

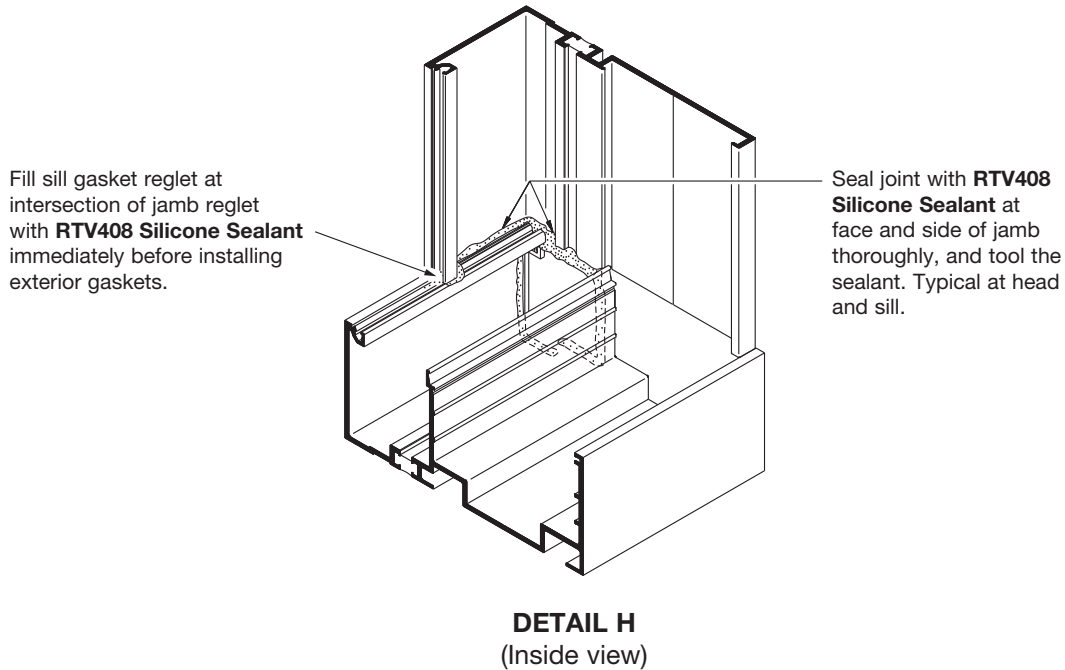

4. Seal around perimeter with **Cat. No. 95C/M64/M66 Sealant**. Perimeter sealing may be done later in exterior glazing installations.

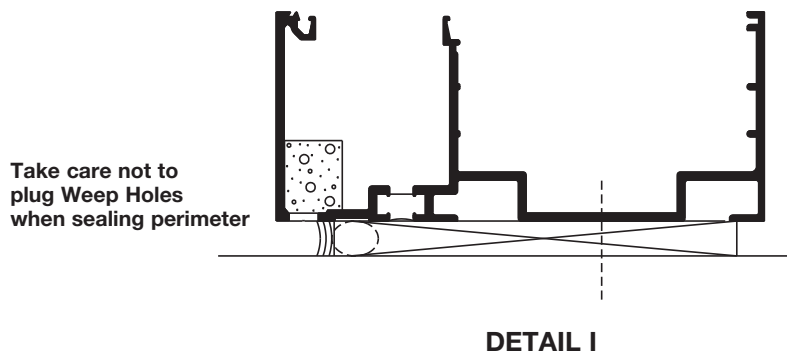

GLAZING – all Series BG and BT

GLASS SIZES*

GLASS HEIGHT : DAYLIGHT OPENING (D.L.O.) + 7/8" (22.2)*

GLASS WIDTH : DAYLIGHT OPENING (D.L.O.) + Glass Bites*

*Glass Bites vary between products. Consult shop drawing or refer to details in the US Aluminum Architectural design manual.

**BG450 and GB520
Glass Bites**

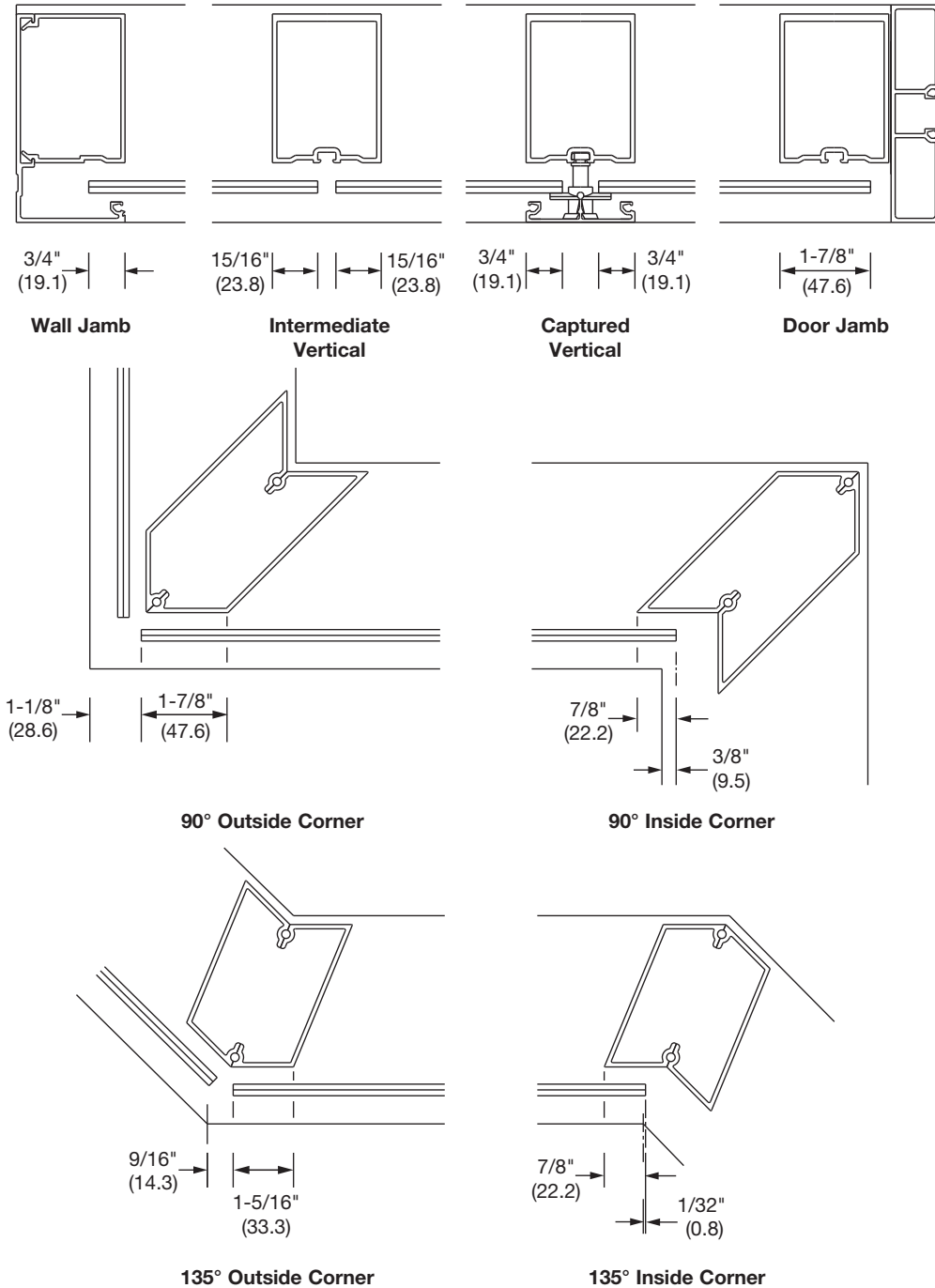

DETAIL J

BG525, BG600, BT525 and BT600
Glass Bites

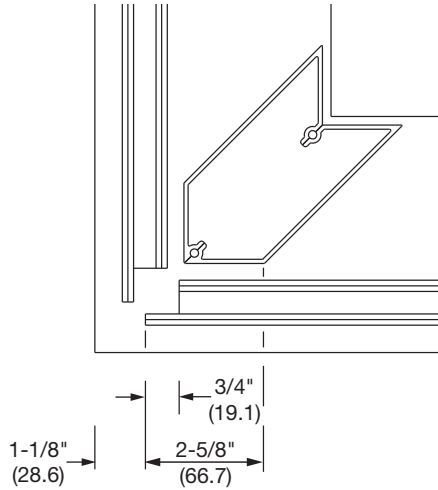
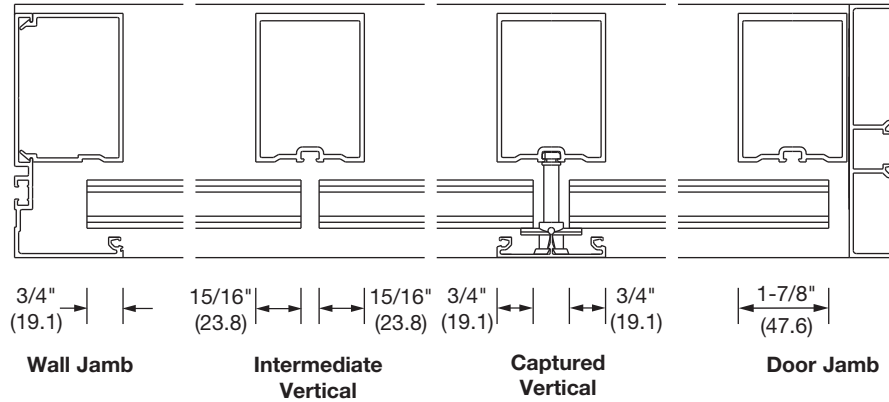

90° Outside Corner

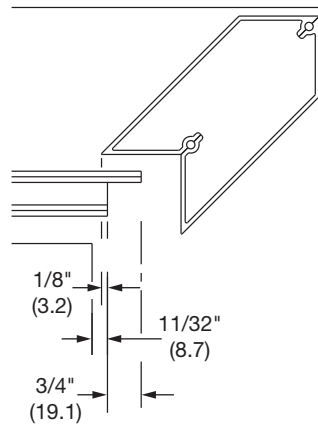

90° Inside Corner

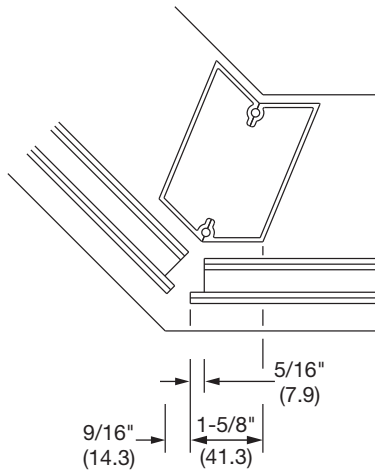

135° Outside Corner

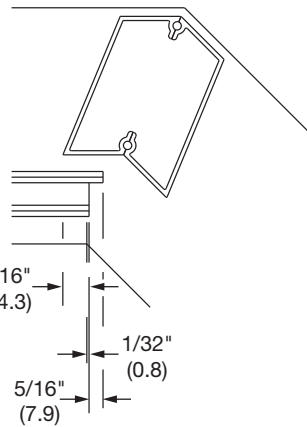

135° Inside Corner

DETAIL K

SERIES BG450, BG520, BG525, BG600, BT525, AND BT600

Elevations with intermediate horizontals must be **EXTERIOR GLAZED** as shown on page 13.

INTERIOR GLAZING INSTALLATION

1. Cut exterior glazing gaskets 1/8" (3.2) longer per foot than aluminum member, to allow for shrinkage.
2. Install gaskets into head, sill and jambs. Vertical gaskets butt into horizontal gaskets.
3. Snap-in wall jamb insert for the first bay. See **DETAIL L**. Seal jamb filler to jamb, as shown on **DETAIL Q**, page 12.

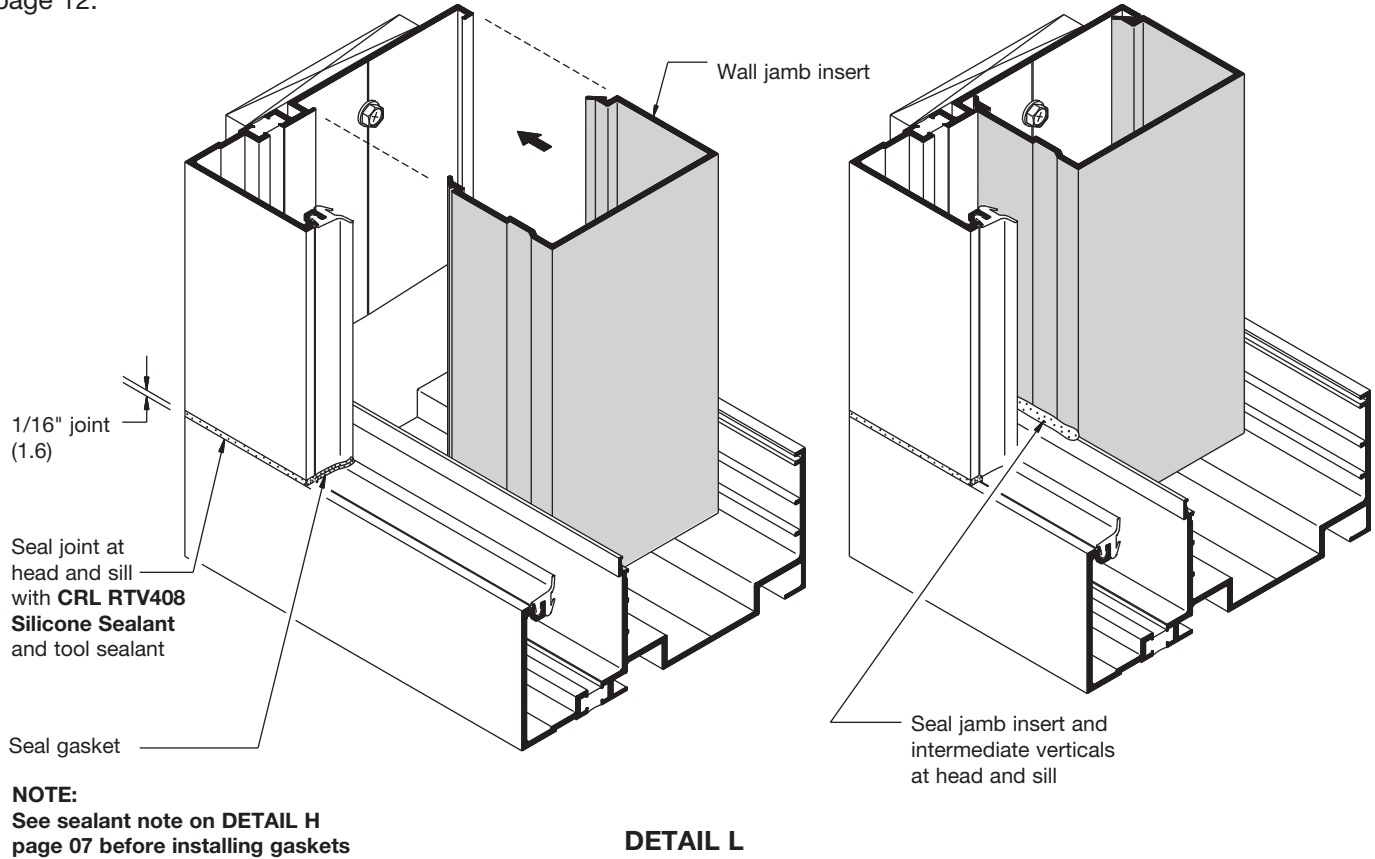

4. Install temporary glass retainers into intermediate verticals. Use one retainer for every 150 lbs. (667.2 N) of load. I.E. if $\text{GLASS HEIGHT} \times \text{GLASS WIDTH} \times \text{WINDLOAD} = 350 \text{ lbs. (1556.9 N)}$ use three retainers per vertical.

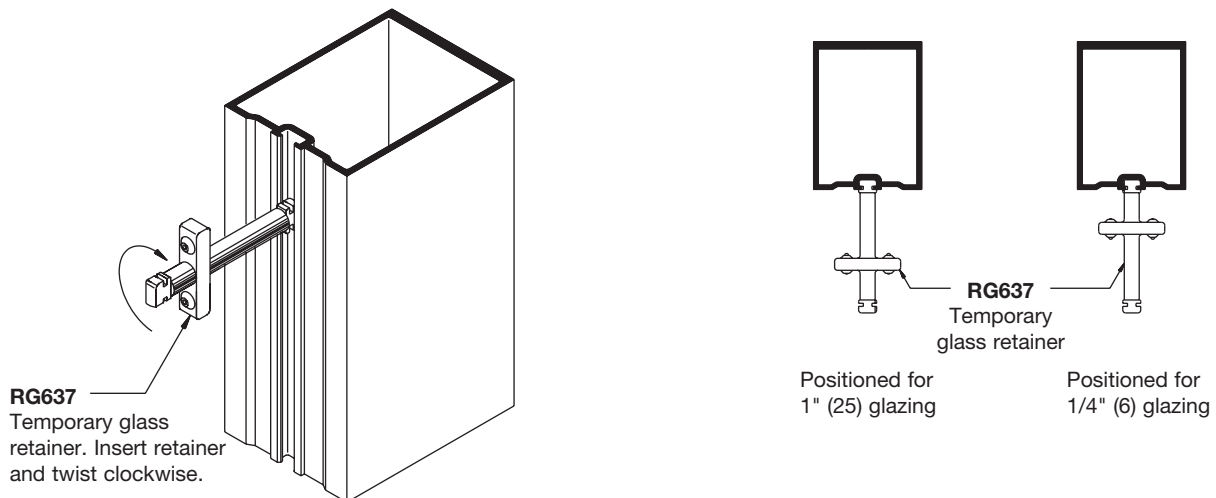

SERIES BG450, BG520, BG525, BG600, BT525, AND BT600

Aluminum and glass are installed simultaneously, bay by bay.
Always protect edges of glass carefully to avoid damage.

5. Install two setting blocks per glass lite into sill gutter at quarter points. See **DETAIL N**.

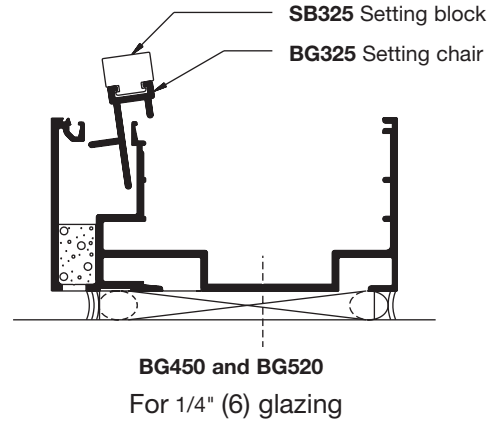
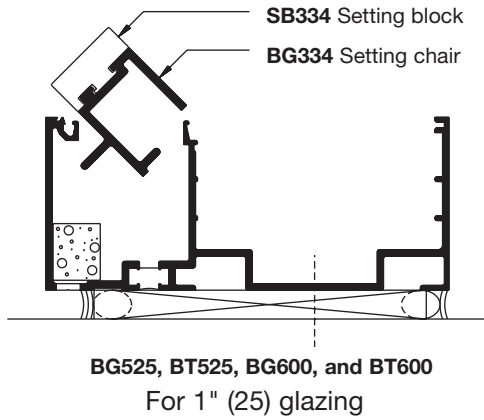

DETAIL N

NOTE: All glazing pockets must be clean of debris before glazing to prevent blockage of weeps or drains.

6. Position first glass lite in place, into header and down on to setting blocks. See **DETAIL O**.
7. Snap-in head and sill fillers. See **DETAIL P**.

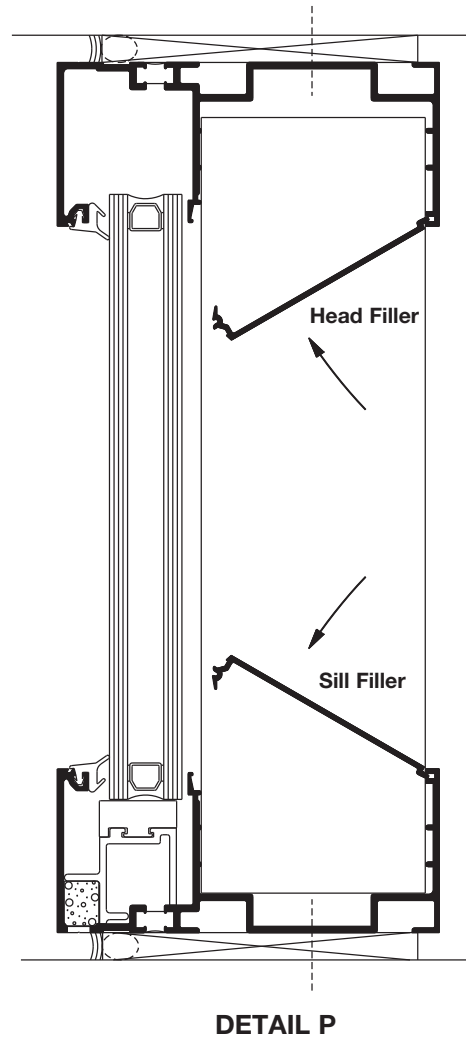
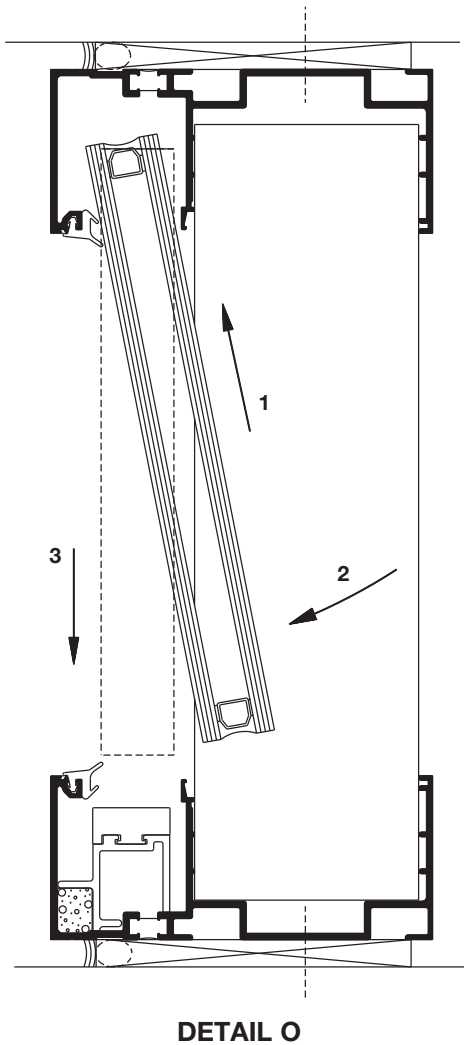

SERIES BG450, BG520, BG525, BG600, BT525, AND BT600

8. Set vertical within head and sill channels and slide it tight into place against head and sill fillers.
See **DETAIL Q**.

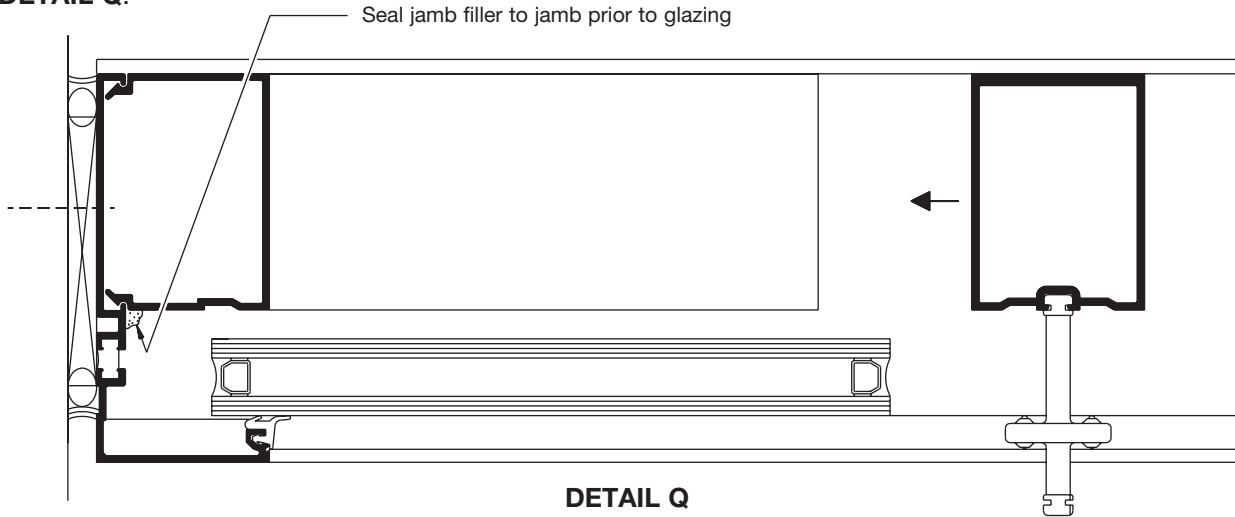

9. Repeat steps 6 to 8 until all bays are glazed. At last glass bay leave wall jamb insert off until glass is installed.
NOTE: A check should be made every four bays to monitor accumulation of horizontal members cutting tolerances
10. Push glazing spacers between glass and aluminum until they lock in place. See **DETAIL Y** on page 16.
Spacers run full height of glass.
11. Install interior gaskets. Go to step 20, page 16.

EXTERIOR GLAZING INSTALLATION

1. Snap-in wall jamb insert. See **DETAIL L**, page 10 similar and **DETAIL Q**.
2. Snap-in head and sill fillers for the first bay.
3. Install vertical and slide it tight against head and sill fillers.
4. Repeat steps 2 and 3 until last bay. At last bay snap-in wall jamb insert before head and sill fillers.
NOTE: A check should be made every four bays to monitor accumulation of horizontal members cutting tolerances
5. Roll horizontals over anchor clips. Match drill two .147" (3.7) dia. holes through anchor clips and secure horizontals with two screws provided. Snap-in bottom filler. See **DETAIL R**.

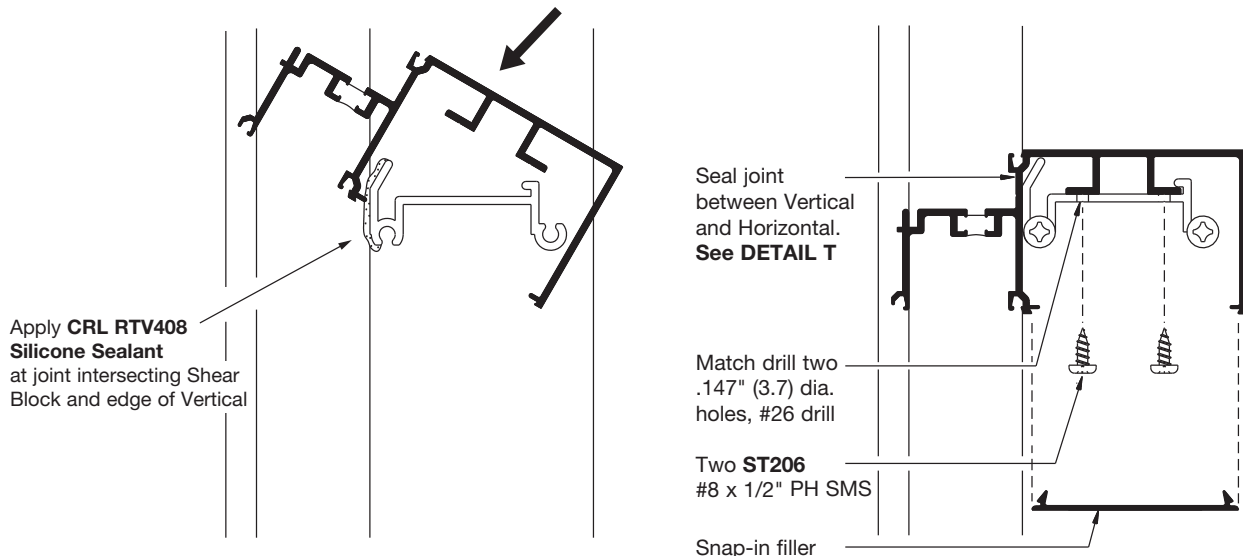

SERIES BG450, BG520, BG525, BG600, BT525, AND BT600

6. Seal joints between horizontals and verticals. See **DETAIL T**. Apply sealant across face of intermediate verticals at water deflectors location. See **DETAIL T**.
7. Water deflectors for wall jambs require that alignment pad at the bottom is removed before installation. **NOTE:** Wall jamb water deflectors fit both, right and left conditions; before removing alignment pad make sure which one of the pads will be at the bottom. See **DETAIL S**.
8. Apply **CRL RTV408 Silicone Sealant** to deflectors contact areas and set them in place. See **DETAILS S and T**.

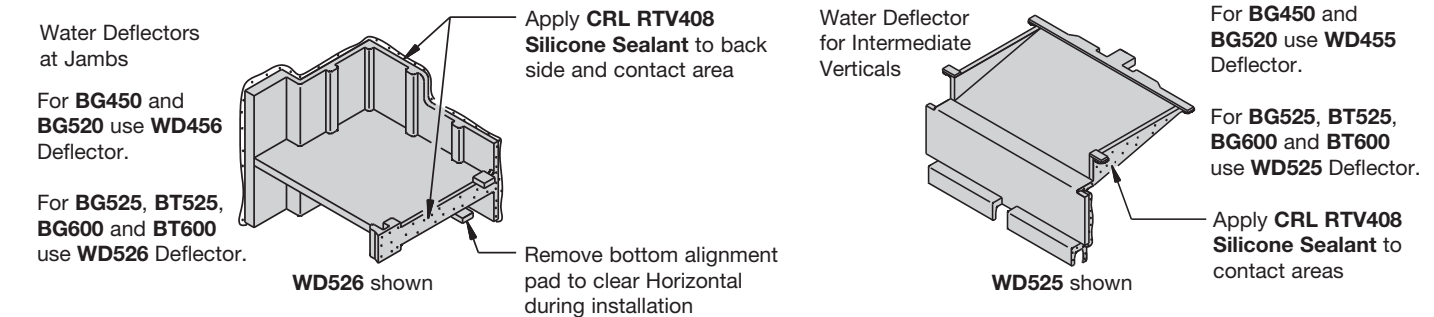

DETAIL S

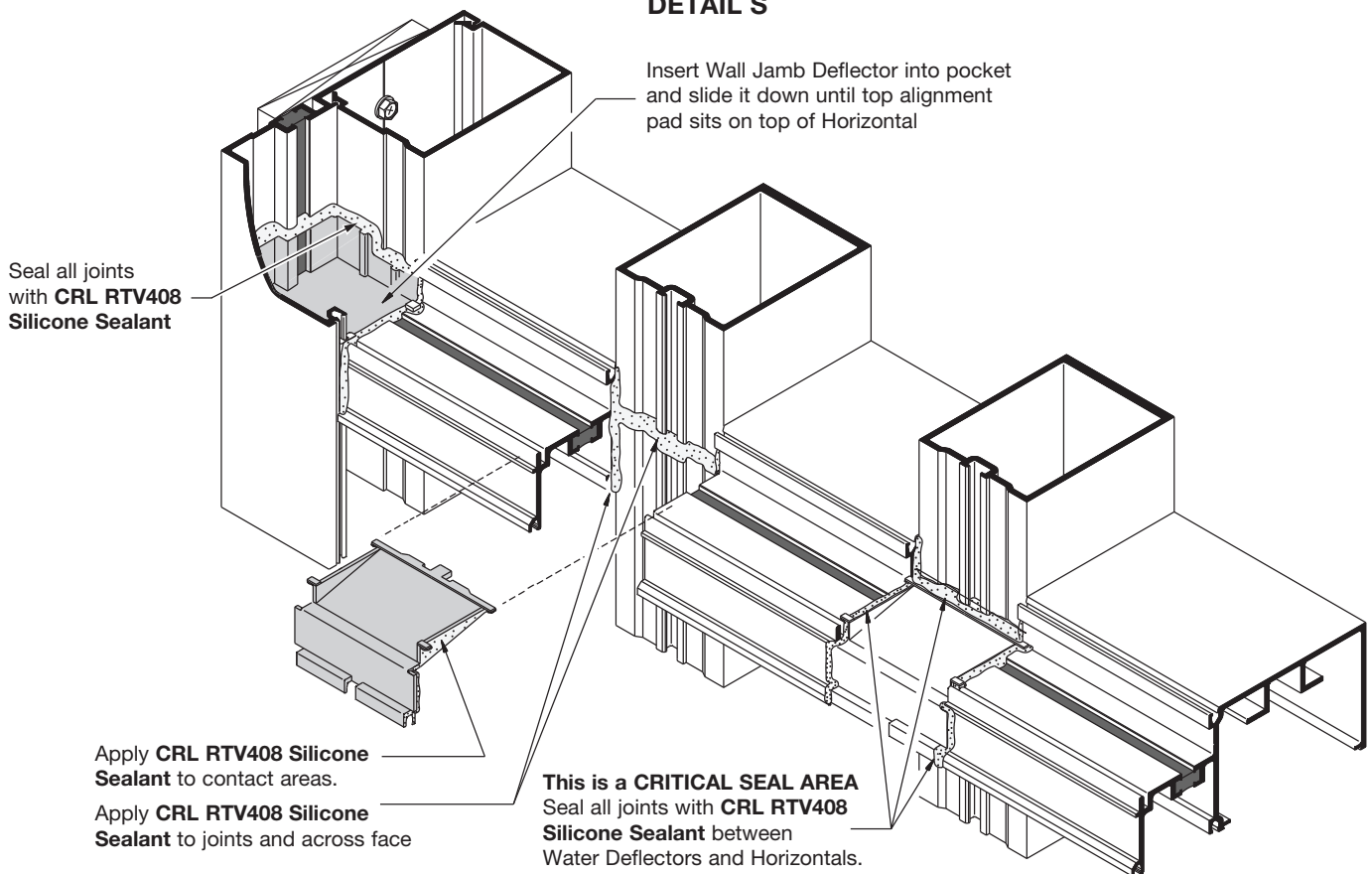

DETAIL T

Always protect edges of glass carefully to avoid damage

9. Install two setting blocks per glass lite into sill gutter at quarter points. See **DETAIL N**, page 11.
10. Cut glazing gaskets 1/8" (3.2) longer per foot of aluminum members, to allow for shrinkage.
11. Install interior gaskets into horizontals, head and sill members. **NOTE: All glazing pockets must be clean of debris before glazing to prevent blockage of weeps or drains.**
12. Set lower glass onto setting blocks, holding 3/8" (9.5) joints between glass lites.

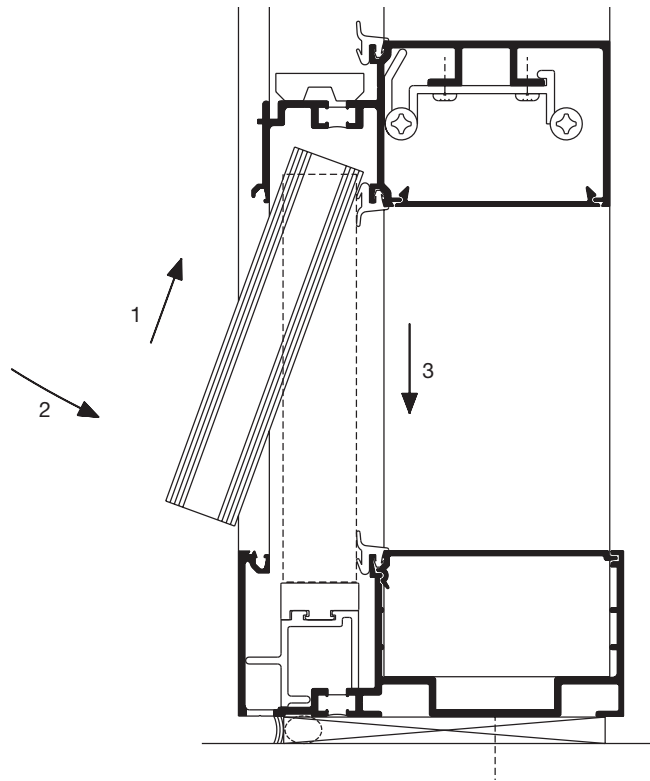

DETAIL U

13. Hold glass in place with temporary retainers. See **DETAIL V**.

Use one retainer for every 150 lbs. (667.2) of load.

If GLASS HEIGHT x GLASS WIDTH x WINDLOAD = 350 lbs. (1556.9 N) use three retainers.

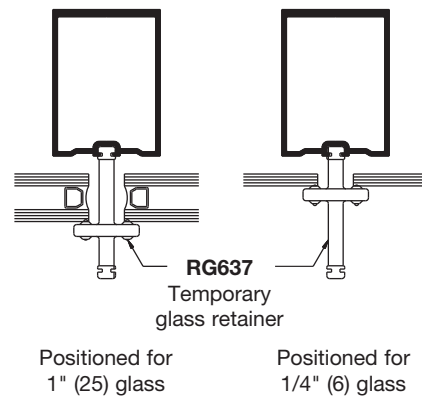
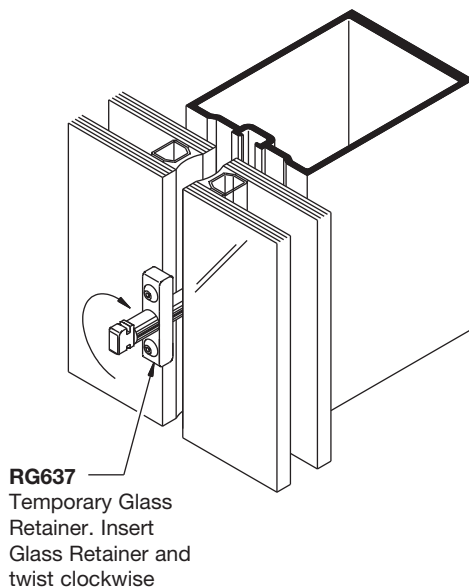

DETAIL V

14. Install two setting blocks for the next upper glass lite at quarter points or as indicated in shop drawings or deadload charts.

15. Set glass in place and repeat process until all glass is installed.

NOTE: Last bay of glass must be installed before previous one.

SERIES BG450, BG520, BG525, BG600, BT525, AND BT600

16. Snap-in continuous horizontal face cover. Maximum cover length 15' (4.6 m) in length. See page 17 for splice joints.

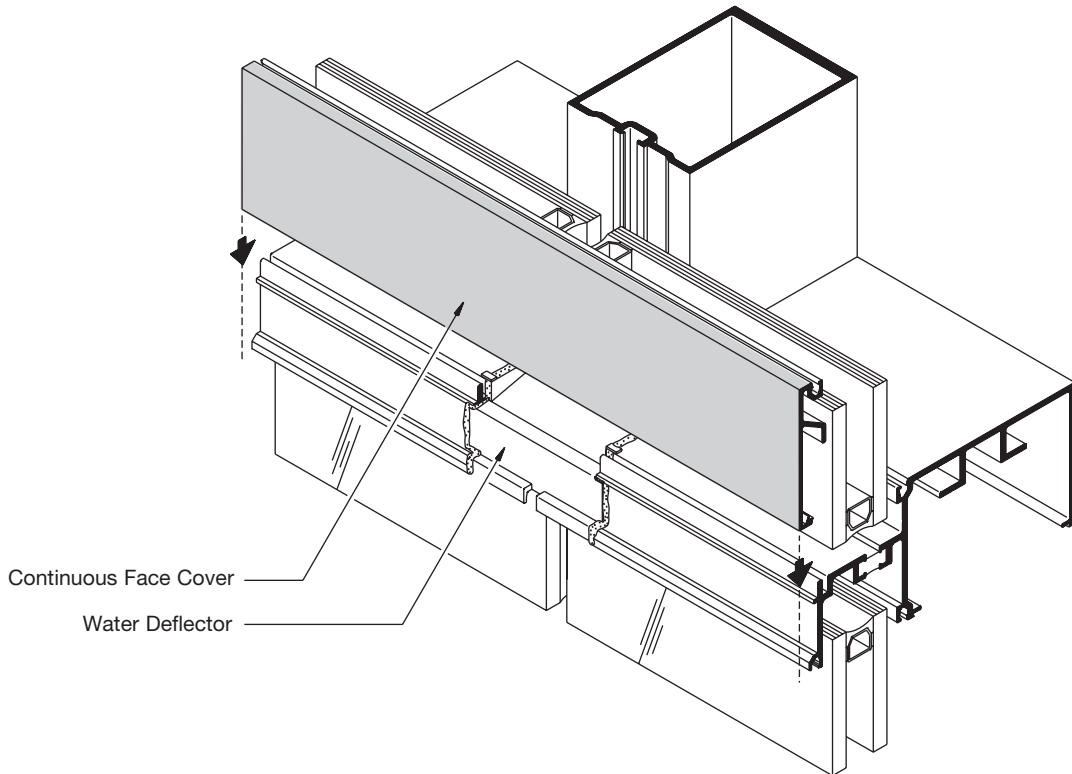

DETAIL W

17. Install exterior glazing gaskets into all members. Horizontal gaskets butt against vertical gaskets. On bottom side of intermediate horizontal notch the dart of the glazing gasket at center of verticals to create a 1/2" (12.7) wide weep hole. See **DETAIL X**.

NOTE: On elevations without intermediate verticals create one weep hole at glass center line.

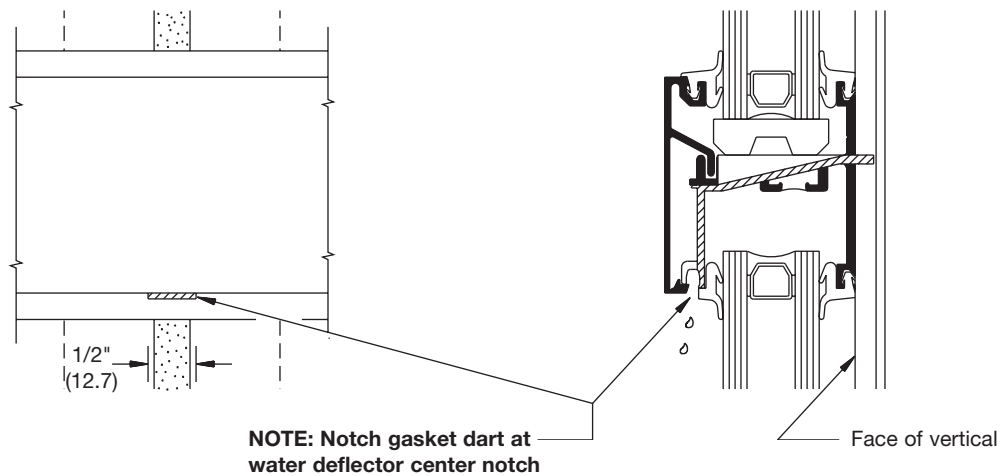

DETAIL X

18. Push glazing spacers between glass and aluminum until they lock into place. Spacers run full height of glass. See **DETAIL Y**.

SERIES BG450, BG520, BG525, BG600, BT525, AND BT600

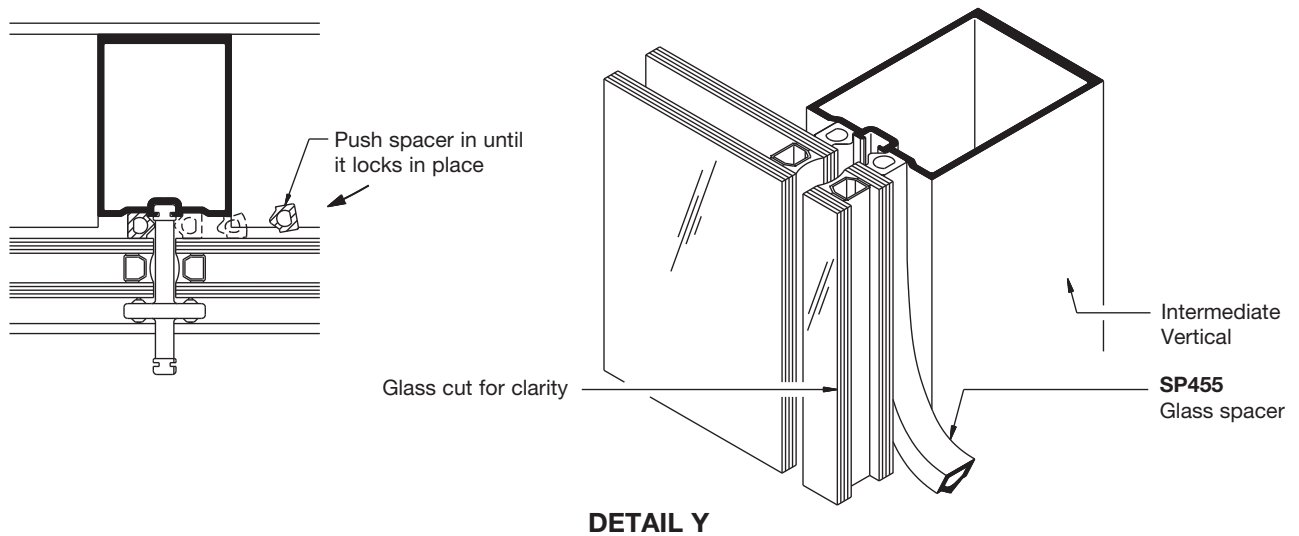

19. Install interior gaskets.

20. Apply structural silicone from the interior.

Always follow silicone manufacturer's instructions and recommendations for surface preparation and silicone application.

21. After structural silicone has fully cured remove temporary retainers, insert open cell polyurethane rod between glass edges, mask glass and aluminum adjacent to joint and apply weather seal.

TRANSITION GLAZING

Vertical transition adaptors run through. Run a bead of sealant in vertical member before setting adaptor. Vertical adaptors are screw applied. **See DETAIL Z.** Roll horizontal adaptors in place. Horizontal adaptors need to be installed when setting glass and held in place temporarily with a piece of gasket. When inside access is not possible upside down adaptor may be held horizontal with a bead of silicone.

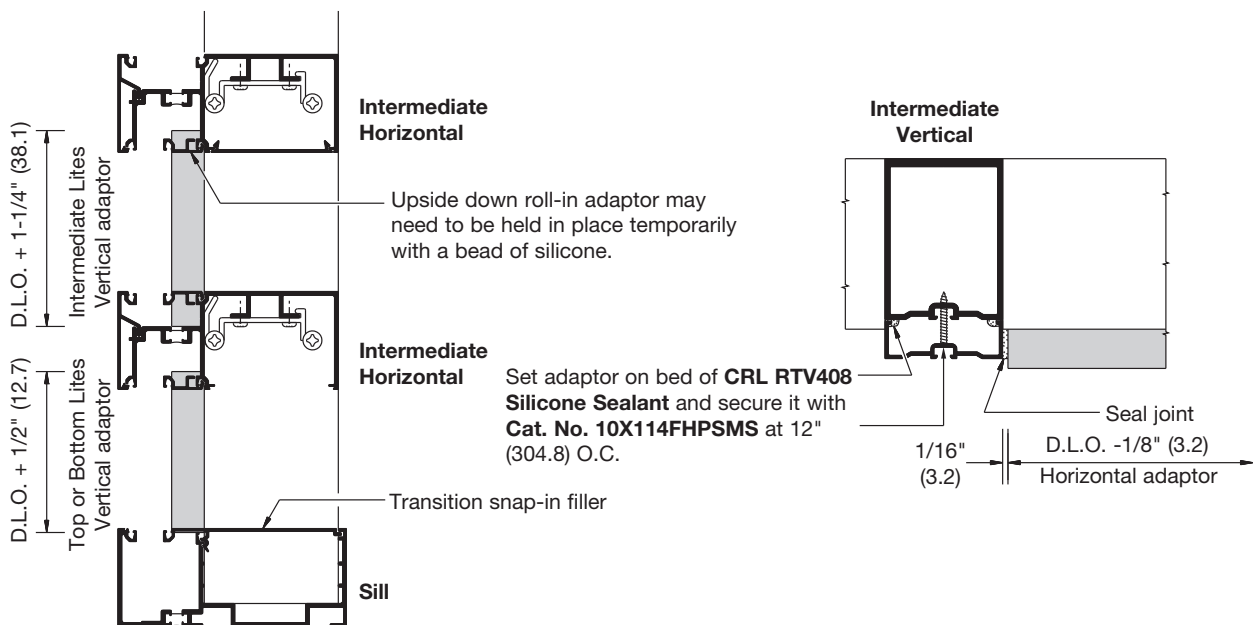

DETAIL Z

EXPANSION JOINTS

Elevations exceeding 24' (7.32 m) in width require splice sleeves for head/sill channel, to accommodate thermal movement. Joint width should be calculated according to job conditions and architectural specifications.

Linear expansion for aluminum, in inches	= Length (") x F° difference in temperature x .0000129
Linear expansion for aluminum, in millimeters	= Length (m) x C° difference in temperature x .02322

Locate splice joints at center line of a vertical mullion.

Elongate holes for installation fasteners at head and sill channels to allow for thermal movement.

Pin head and sill channels at one point only per cut length. (This hole is not elongated). It is recommended that exterior gaskets run continuous through splice joints. Seal joint with **Cat. No. 95C Silicone** and tool sealant.

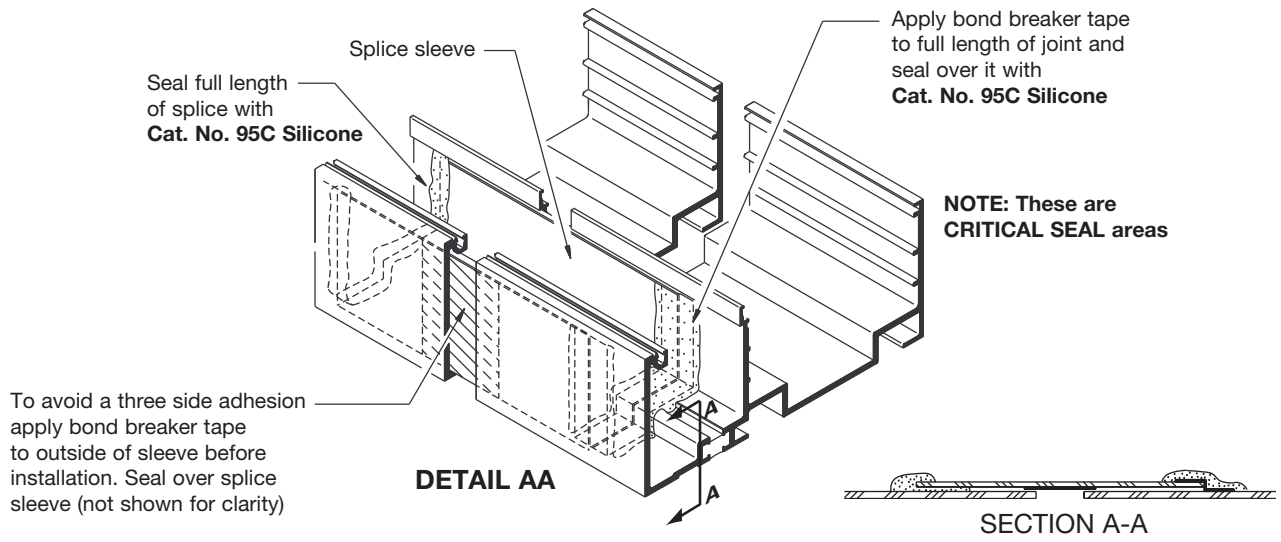

To avoid a three side adhesion apply bond breaker tape to outside of sleeve before installation. Seal over splice sleeve (not shown for clarity)

DETAIL AA



Sill splice joint shown with **Cat. No. 95C Silicone**
(Head splice joint similar)

Horizontal and perimeter face covers exceeding 15' (4.5 m) in length must be spliced. Center splices in vertical members as shown. **See DETAIL BB.**

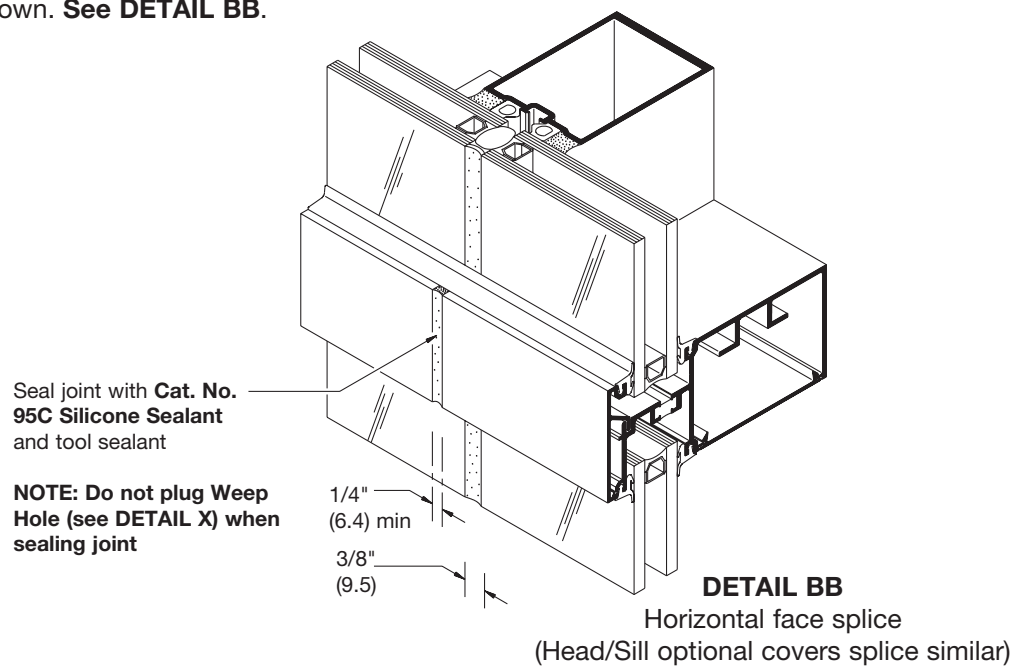

DETAIL BB
Horizontal face splice
(Head/Sill optional covers splice similar)

CORNER CONDITIONS

Head and sill members should be mitered as required.

Corner members should be cut same length as verticals.

Head and sill members **must be pinned to structure on both sides of corner, to prevent movement of mitered joint.** (Do not elongate the hole where is pinned).

Elevations with corners at both ends require a splice joint to accommodate thermal movement.

See DETAIL CC.

1. Install mitered head and sill at one side of corner and secure them to structure.
2. Butt edge of other half with silicone and install. Seal joint at gutter area.

See DETAIL DD.

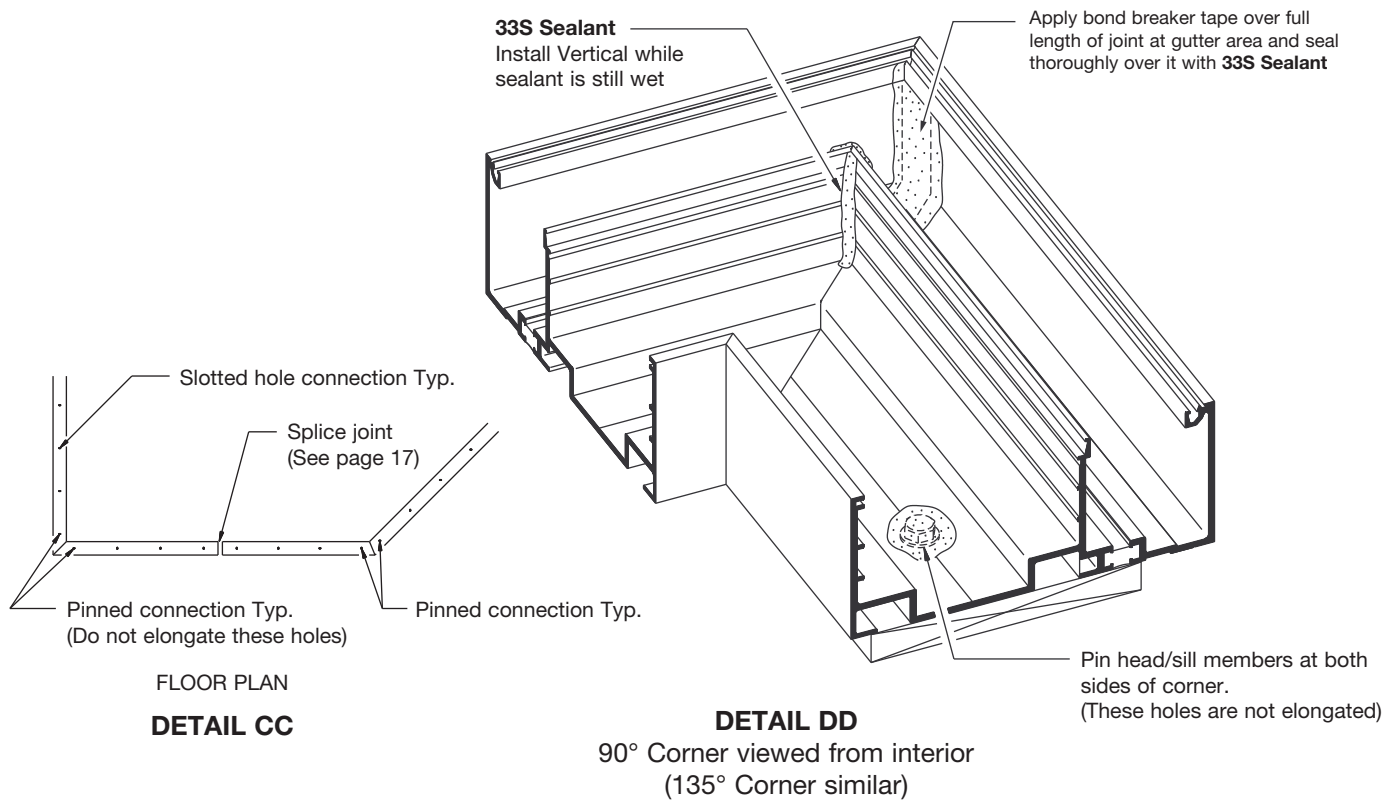

3. Set corner components in place before snapping-in head and sill fillers.

See DETAIL EE.

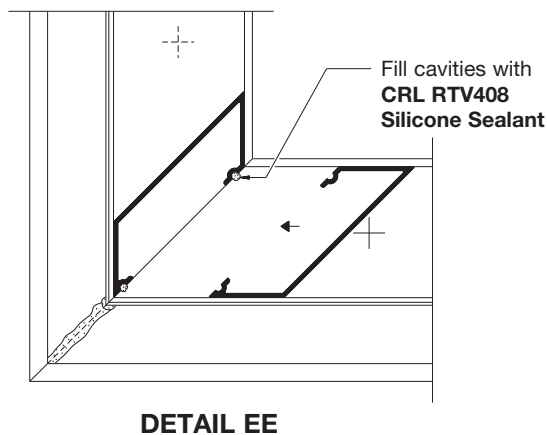

DETAIL EE

SERIES BG450, BG520, BG525, BG600, BT525, AND BT600

4. Use **Cat. No. V211212** dual adhesive tape to glaze corner conditions. Always install tape starting 1/2" from the edge of the corner member to provide a 1/2" wide silicone joint. **See DETAIL FF.**

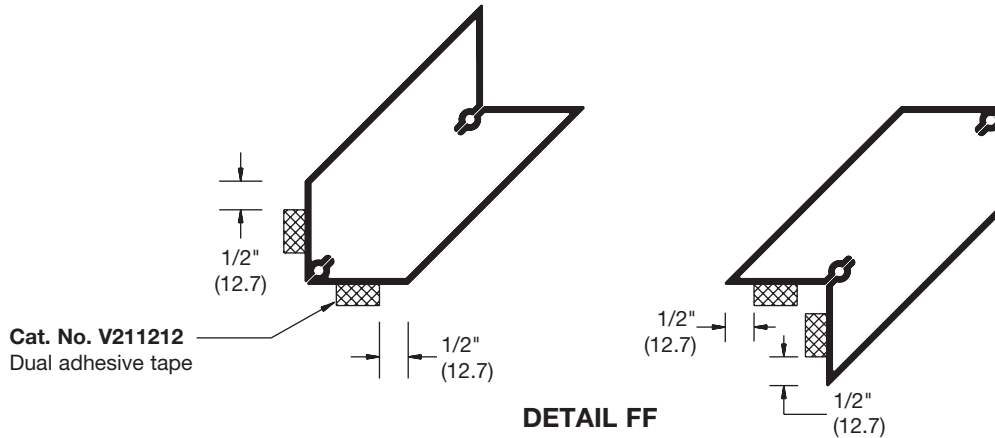

5. Press glass firmly against tape. In most conditions tape provides sufficient support during silicone curing time.

CAPTURED VERTICALS

Optional face covers for vertical members are available. Face covers run between horizontal covers and snap over thermal clips.

Install clips between glass lites and turn to the right (clockwise). Clips should be located 2" (50.8) from horizontal face covers and approximately 12" (304.8) O.C. **See DETAIL GG.**

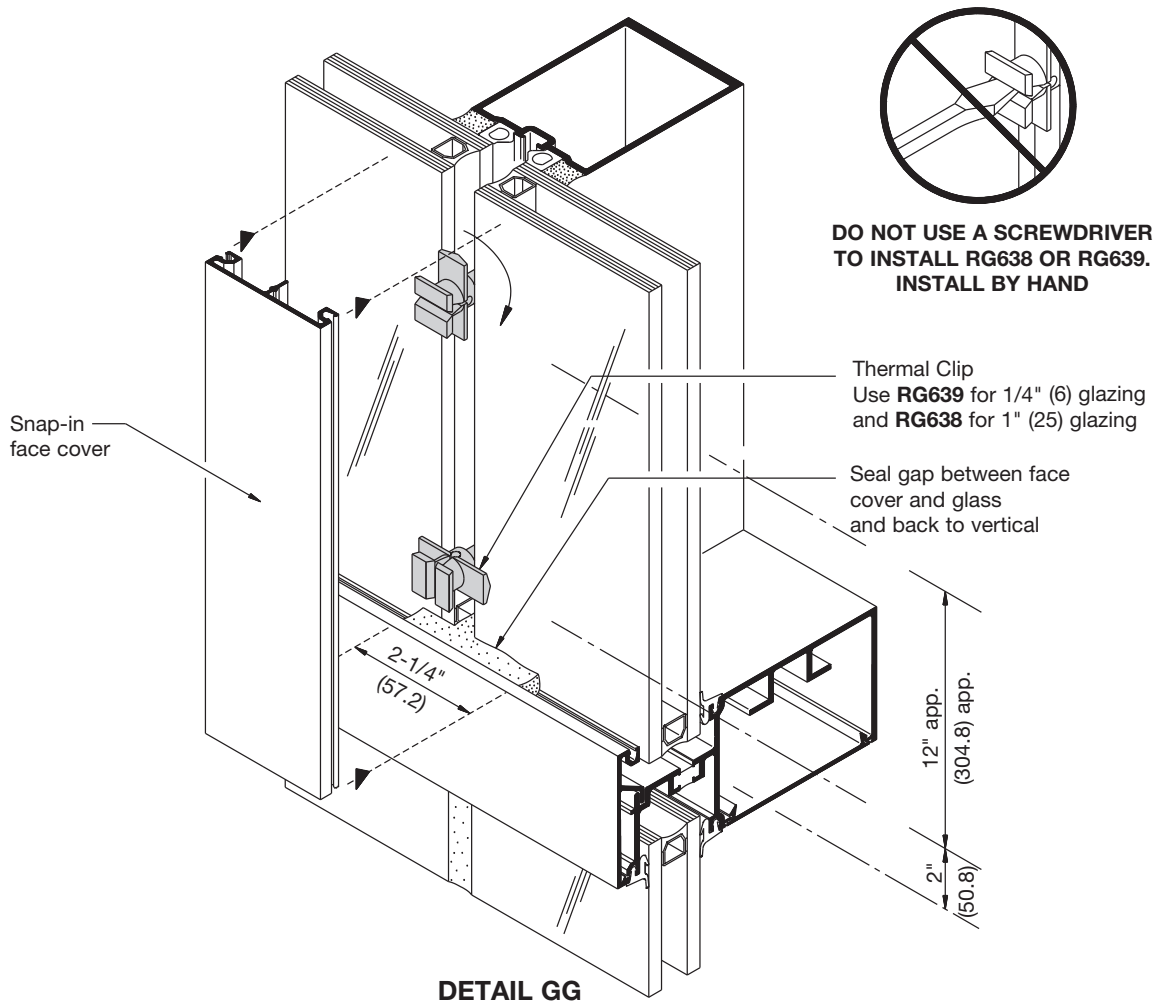

OPTIONAL PERIMETER FACE COVERS

NOTE: Optional face covers must be installed before exterior glazing gaskets.

Head and sill covers extend 3/32" (2.4) past wall jamb. See **DETAIL HH**.

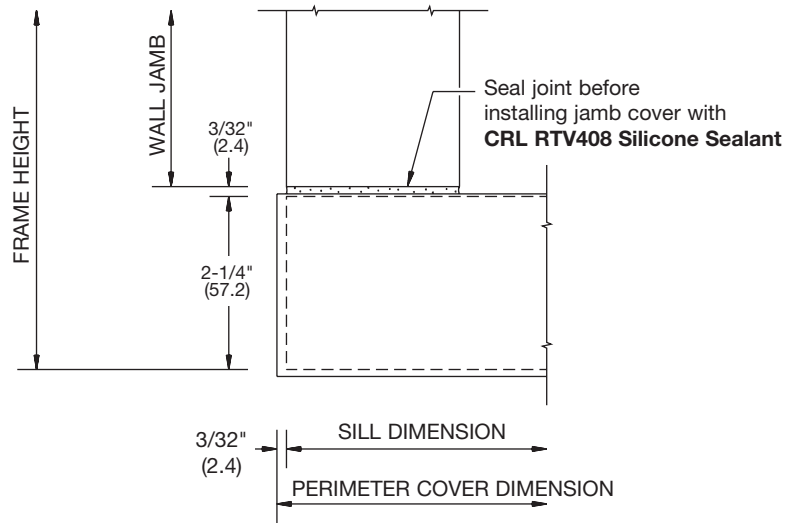

DETAIL HH

1. Snap-in head and sill covers before jamb installation. See **DETAIL II**. Care must be taken to prevent damage of face covers during installation. Use a piece of wood such as a 2" x 4" x 12" (50 x 100 x 300) and a **Cat. No. ST57534** soft face no-bounce hammer.
2. Seal joints between wall jamb and head/sill covers immediately before installing jamb covers.

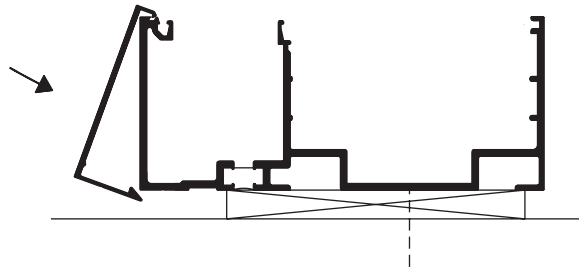

DETAIL II

3. Drill two 5/16" (7.9) dia. holes in cover using sill Weep Holes as pilots. See **DETAIL JJ**.

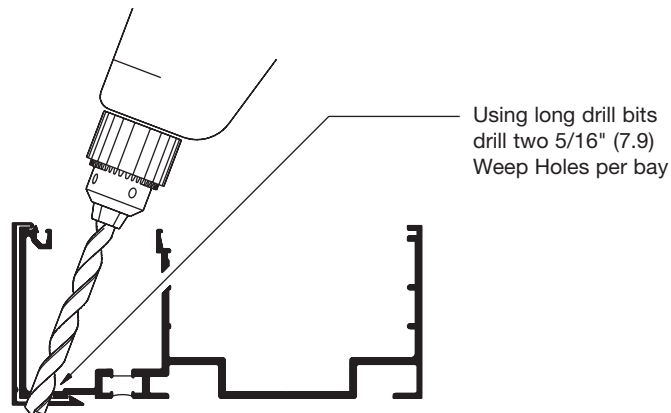

DETAIL JJ

DOOR SUBFRAME INSTALLATION

1. Cut door subframe to frame height plus bottom caulk joint size.

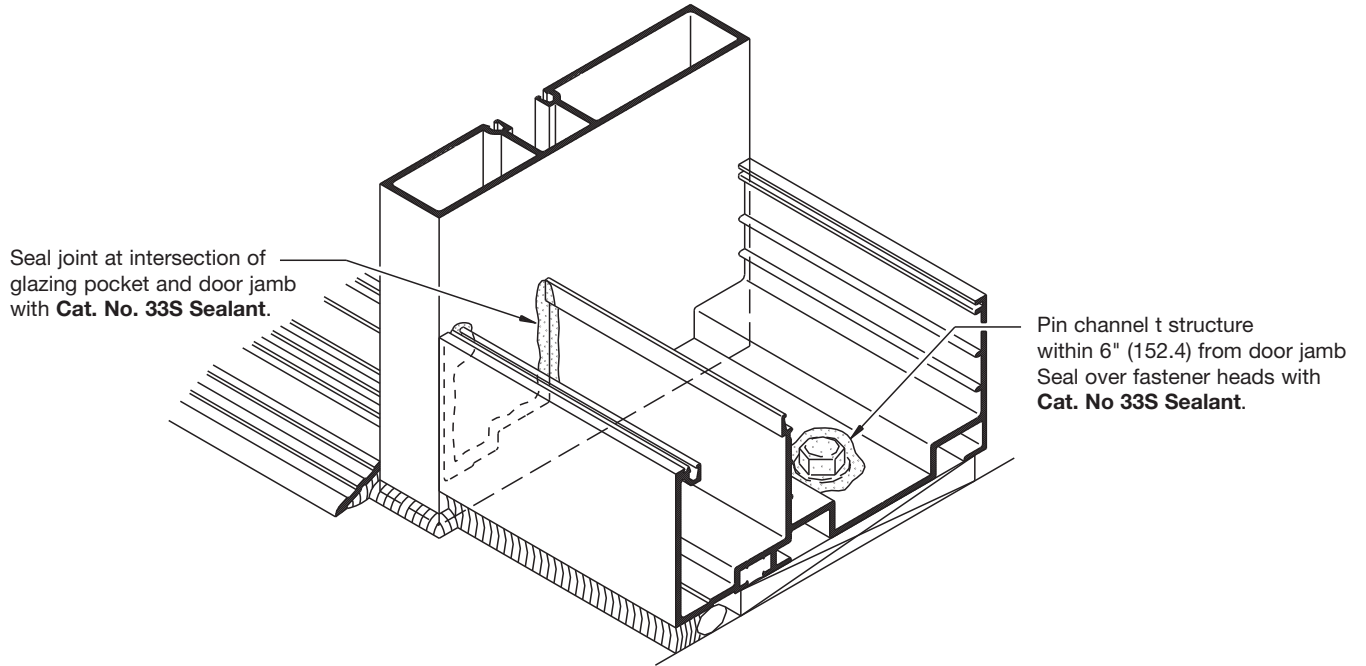

DETAIL KK

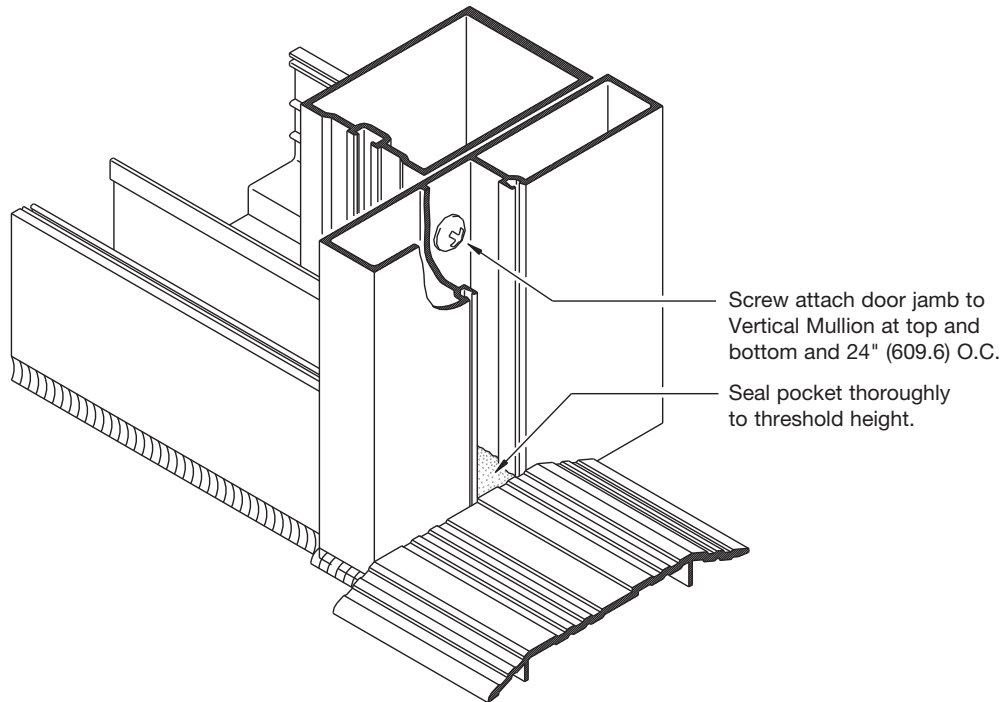

DETAIL LL

NOTE: See ENTRANCE DOOR and FRAME section for door installation.

CAL US ALUMINUM GUIDE TO SEALANTS

WATERPROOFING

- **CRL 33S ACETIC CURE SILICONE**

NOTE: Not for use near insulating glass units with butyl sealant.

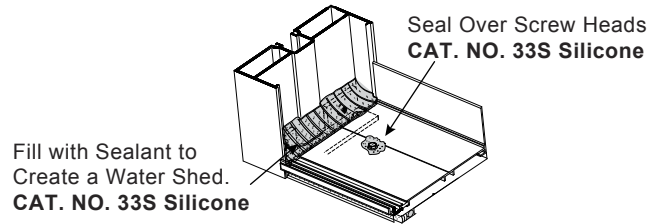

Sill to Subsill, End Dams, Screw Heads, and Threshold to Door Frame Sealing.

JOINT ADHESIVE

- **CRL RTV408 NEUTRAL CURE SILICONE**

NOTE: I.G. butyl contact OK.

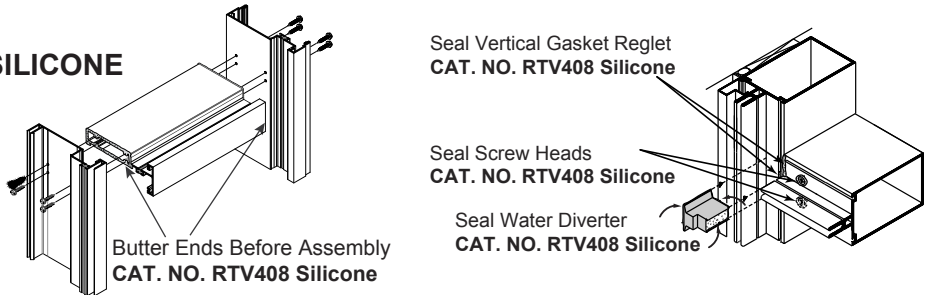

Small Joints, End Joints and Buttered Surfaces, Water Diverters and Reglet Fills.

PERIMETER

- **CRL 95C NEUTRAL CURE SILICONE**
- **CRL M64 (SMOOTH) MODIFIED POLYURETHANE**
- **CRL M66 (TEXTURED) MODIFIED POLYURETHANE**

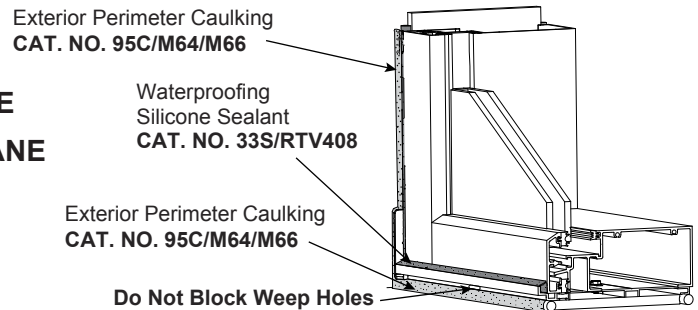

Perimeter Seals, Expansion Joints, Sill and Threshold Beds, Concrete, Wood, and Steel Openings.

EXPANSION

- **CRL 95C NEUTRAL CURE SILICONE**

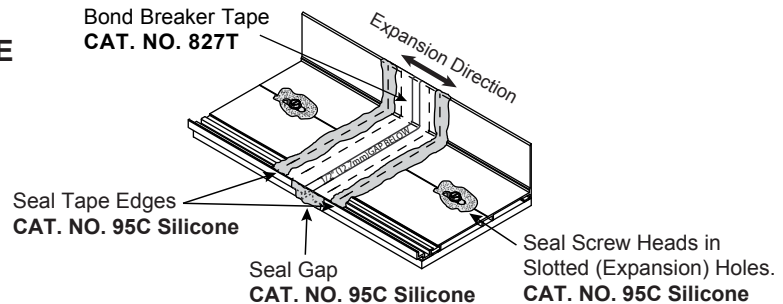

Expansion Joints.

STRUCTURAL

- **ALL STRUCTURAL SEALANTS REQUIRE TESTING AND APPROVAL.**

Glass-to-Glass or Glass-to-Metal.



JOB SITE ESSENTIALS

Helpful Tools and Supplies for Installing CRL U.S. Aluminum Entrances, Storefronts, Windows, and Curtain Wall Systems



CRL 95C Silicone Building Sealant



CRL RTV408 Neutral Cure Silicone



CRL 33S Acetic Cure Silicone Sealant



CRL M64 Smooth Texture Modified Polyurethane Construction Sealant



CRL M66 Grainy Texture Modified Polyurethane Construction Sealant



CRL 12:1 Ratio Strap Frame Caulking Gun CAT. NO. GA1203



CRL BOCBR Series Open Cell Backer Rod



CRL Backer Rod Roller Tool CAT. NO. SBRR



CRL Vacuum Cup CAT. NO. S7950



CRL Saint-Gobain/Norton V2100 Thermalbond® Structural Glazing Spacer Tape

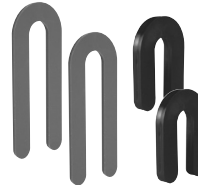

CRL PHS Series Plastic Horseshoe Shims



CRL Digital Laser Level Tool CAT. NO. 406065



CRL Cordless Screwdriver CAT. NO. LD823



CRL Portable Miter Saw 10" CAT. NO. LS1040

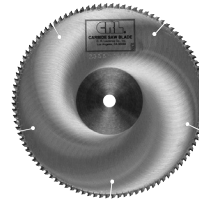

CRL Nordic Carbide Saw Blade CAT. NO. CSB10X100AX

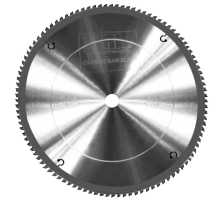

CRL Cougar Carbide Saw Blade CAT. NO. CT10X100



CRL Door Jack CAT. NO. DJ1



CRL Complete Set of Seven All Stainless Steel Spatulas CAT. NO. AB958G



CRL Portable Ladder CAT. NO. 6206



CRL Hard Hat CAT. NO. ES3452



CRL Soft-Face Power Hitter CAT. NO. ST57532

SERIES BG450, BG520, BG525, BG600, BT525, AND BT600



CRL Bond Breaker Tape



CRL Glass Cutter
CAT. NO. TC17B



CRL Running Pliers
CAT. NO. PPG1



CRL Utility Knife
CAT. NO. K82



CRL Gasket Roller
CAT. NO. VR10

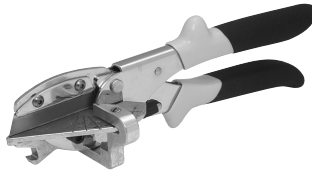

CRL Gasket Cutter
CAT. NO. MC80N



CRL Glass Cleaner
CAT. NO. 1973



CRL Glass Wipes
CAT. NO. 1550

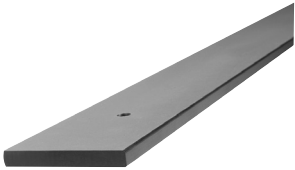

CRL 96" Phenolic Straight Edge
CAT. NO. SEP96



CRL Glazier's Rule Holder
CAT. NO. RH670



CRL Phenolic L Square
CAT. NO. L48



CRL Spring Clamp
CAT. NO. JC3202HT



CRL Tape Measure
CAT. NO. 54125



CRL Glass Marking Pencil
CAT. NO. GM44



CRL Belt Sander
CAT. NO. LD321



CRL Glass Grinding Belts



CRL Gloves
CAT. NO. KF1TL



CRL Utility Knife Blades
CAT. NO. 1992C



CRL Cordless Driver/Drill
CAT. NO. LD147



CRL All Terrain Dolly
CAT. NO. ATD1