

INSTALLATION AND GLAZING INSTRUCTIONS

SERIES 400, 450, 451, AND IT451

CENTER GLAZED SYSTEMS

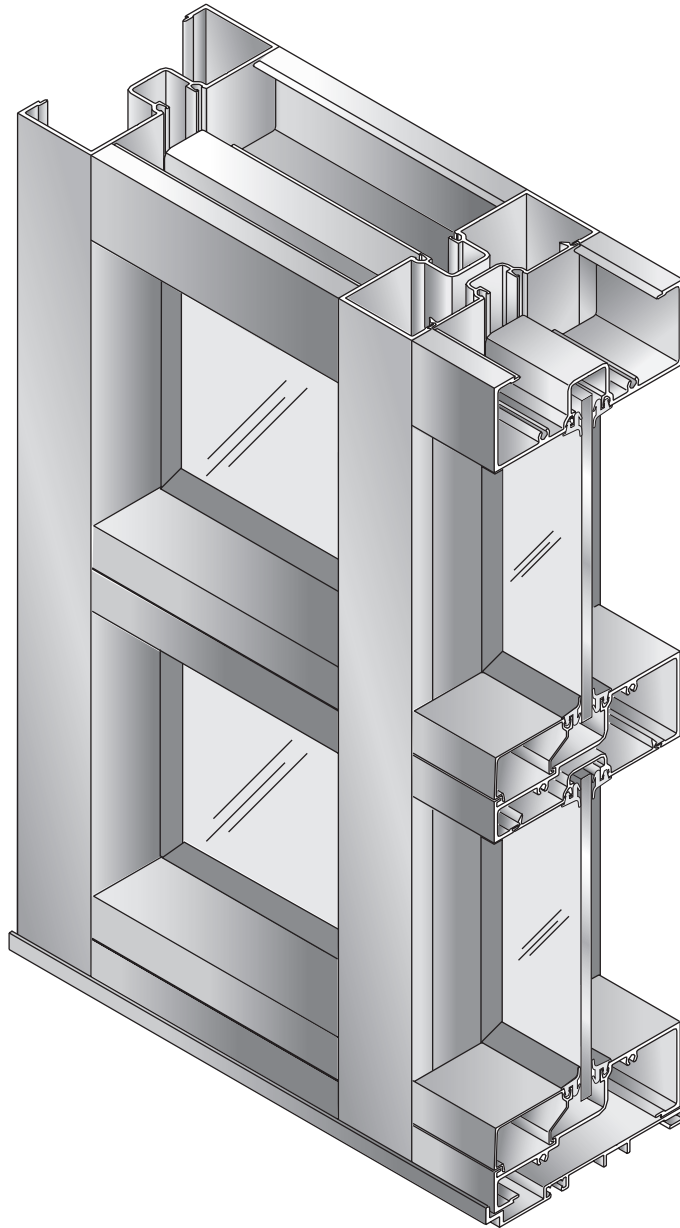

Phone: (800) 262-5151 • Fax: (866) 262-3299
crlaurence.com • usalum.com • crl-arch.com

HANDLING, STORAGE, AND PROTECTION OF ALUMINUM

The following precautions are recommended to protect the material against damage. Following these precautions will help ensure early acceptance of your products and workmanship.

A. HANDLE CAREFULLY.

All aluminum materials at job site must be stored in a safe place, well removed from possible damage by other trades. Cardboard wrapped or paper interleaved materials must be kept dry.

B. CHECK ARRIVING MATERIALS.

Check for quantity counts and keep records of where various materials are stored.

C. KEEP MATERIALS AWAY FROM WATER, MUD, AND SPRAY.

Prevent cement, plaster or other materials from damaging the finish.

D. PROTECT THE MATERIALS AFTER ERECTION.

Protect erected frame with polyethylene or canvas splatter screen. Cement, plaster, terrazzo, other alkaline solutions, and acid based materials used to clean masonry are harmful to the finish. ***If any of these materials come in contact with the aluminum, IMMEDIATELY remove with water and mild soap.***

The rapidly changing technology within the architectural aluminum products industry demands that U.S. Aluminum reserve the right to revise, discontinue or change any product line, specification or electronic media without prior written notice.

NOTE: Dimensions in parentheses () are millimeters unless otherwise noted.

GENERAL INSTALLATION NOTES

Recommended guidelines for all installations:

- 1. REVIEW CONTRACT DOCUMENTS.** Check shop drawings, installation instructions, architectural drawings, and shipping lists to become thoroughly familiar with the project. The shop drawings take precedence and include specific details for the project. Note any *field verified* notes on the shop drawings prior to installing. The installation instructions are of a general nature and cover most conditions.
- 2. INSTALLATION.** All materials are to be installed plumb, level, and true.
- 3. BENCH MARKS.** All work should start from bench marks and/or column lines as established by the architectural drawings and the general contractor with guaranteed accuracy. Working from these datum points and lines determine:
 - a) The plane of the wall in reference to offset lines provided on each floor.
 - b) The finish floor lines in reference to bench marks on the outer building columns.
 - c) Mullion spacing from both ends of masonry opening to prevent dimensional build-up of daylight opening.
- 4. FIELD WELDING.** All field welding must be adequately shielded to avoid any splatter on glass or aluminum. Results will be unsightly and/or structurally unsound. Advise general contractor and other trades accordingly. All field welds of steel anchors must receive touch-up paint (zinc chromate) to avoid rust.
- 5. SURROUNDING CONDITIONS.** Make certain that construction which will receive your materials is in accordance with the contract documents. If not, notify the general contractor in writing and resolve differences before proceeding with work.
- 6. ISOLATION OF ALUMINUM.** Aluminum to be placed in direct contact with uncured masonry or incompatible materials should be isolated with a heavy coat of zinc chromate or bituminous paint.
- 7. SEALANTS.** Sealants must be compatible with all materials with which they have contact, including other sealant surfaces. Consult with sealant manufacturer for recommendations relative to joint size, shelf life, compatibility, cleaning, priming, tooling, adhesion, etc. It is the responsibility of the **Glazing Contractor** to submit a statement from the sealant manufacturer indicating that glass and glazing materials have been tested for compatibility and adhesion with glazing sealants, and interpreting test results relative to material performance, including recommendations for primers and substrate preparation required to obtain adhesion. The chemical compatibility of all glazing materials and framing sealants with each other and with like materials used in glass fabrication must be established. **This is required on every project.**
- 8. FASTENING.** Within the body of these instructions "fastening" means any method of securing one part to another or to adjacent materials. Only those fasteners used within the system are specified in these instructions. Due to the varying perimeter conditions and performance requirements, perimeter and anchor fasteners are not specified in these instructions. For perimeter and anchor fasteners refer to the shop drawings or consult the fastener supplier.
- 9. BUILDING CODES.** Due to the diversity in state/provincial, local, and federal laws and codes that govern the design and application of architectural products, it is the responsibility of the individual, architect, owner, and installer to assure that products selected for use on projects comply with all the applicable building codes and laws. U.S. Aluminum exercises no control over the use or application of its products, glazing materials, and operating hardware, and assumes no responsibility thereof.
- 10. EXPANSION JOINTS.** Expansion joints and perimeter seals shown in these instructions and in the shop drawings are shown at normal size. Actual dimensions may vary due to perimeter conditions and/or difference in metal temperature between the time of fabrication and the time of installation. Gaps between expansion members should be based on temperature at time of installation.
- 11. WATER HOSE TEST.** As soon as a representative amount of the wall has been glazed (500 square feet or 46.5 m²) a water hose test should be conducted in accordance with AAMA 501.2 specifications to check the installation. On all jobs the hose test should be repeated every 500 square feet (46.5 m²) during the glazing operation.
- 12. COORDINATION WITH OTHER TRADES.** Coordinate with the general contractor any sequence with other trades which offset curtain wall installation (i.e. fire proofing, back-up walls, partitions, ceilings, mechanical ducts, converters, etc.).
- 13. CARE AND MAINTENANCE.** Final cleaning of exposed aluminum surfaces should be done in accordance with AAMA 609.1 for anodized aluminum and 610.1 for painted aluminum.

SERIES 400, 450, 451, AND IT451

- 14. SEALANTS.** Check shop drawings, installation instructions, architectural drawings and shipping lists to become thoroughly familiar with all sealants referenced in these instructions, which must be a one part elastomeric Acetic or Neutral Cure silicone and must be applied according to the silicone manufacturer's recommendations.
- 15. APPLICATION.** Structural silicone must be applied from the interior and weatherseal from the exterior after the interior structural silicone has fully cured.
- 16. MAXIMUM ALLOWABLE STRESS ON SILICONE.** The maximum allowable size of the glass lite is controlled by the width and depth of the silicone joint combined with the specified design windload (PSF or Pa). The stress on the structural silicone must not exceed 20 PSI (137 KPa) for a 6:1 safety factor. Check Structural Silicone Chart in the Architectural Design Manual for this product series.
- 17. ARCHITECT.** It is the responsibility of the architect to secure approval of the system and request from the Glazing Contractor the compatibility and adhesion test reports described below.
- 18. GLAZING CONTRACTOR.** It is the responsibility of the glazing contractor to submit a statement from the sealant manufacturer indicating that glass and glazing materials have been tested for compatibility and adhesion with glazing sealants and interpreting test results relative to material performance, including recommendations for primers and substrate preparation required to obtain adhesion. The chemical compatibility of all glazing materials and framing sealants with each other and with like materials used in glass fabrication must be established. This is required on every project.
- 19. U.S. ALUMINUM.** It is the responsibility of U.S. Aluminum to supply a system to meet the architect's specifications.

INSTALLATION INSTRUCTIONS

Frames may be shop fabricated and shipped to job site partially or totally assembled. Systems feature screw race or anchor clip joinery for interior or exterior glazing. Screw race frames are fabricated in units and snapped together. Each unit must have at least one vertical deep pocket to allow for glazing.

Never allow two shallow pockets to face each other. Plan units accordingly. **See DETAILS A and B.**

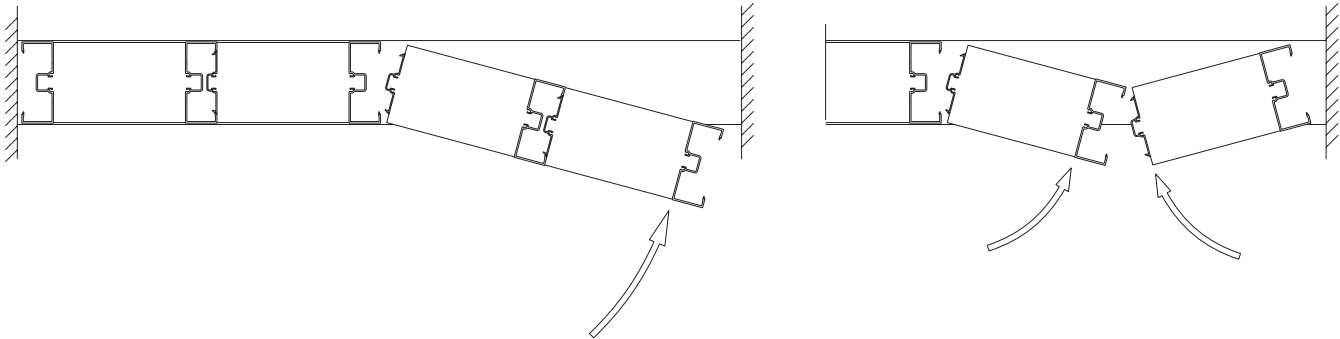

DETAIL A

Expansion mullions must be used in long run elevations to accommodate thermal movement. **See page 31.** Units sit into a continuous subsill. Shimming of subsill is required for leveling.

NOTE: SERIES 450 for 1/4" (6) glass is shown in these instructions.
SERIES 400 for 1/4" (6) glass, 451 for 1" (25) glass and IT451 for 1" (25) glass are similar.

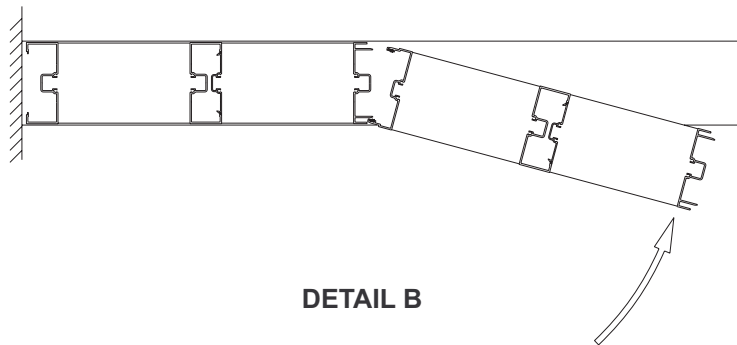

DETAIL B

FABRICATION AND ASSEMBLY

1. Measure Rough Opening to determine cut length of frame components. Allow a minimum clearance of 1/2" (12.7) at header and 3/8" (9.5) at wall jambs and subsill. Extra clearances may be necessary to accommodate building tolerances. When using optional AF100 Sill Flashing, allow 1/4" (6.3) minimum at head.
2. Cut subsill to size: Overall Frame Width plus 1/8" (3.2). Subsill must extend 1/8" (3.2) exterior of last wall jamb to allow last panel installation. Subsill runs through. **This applies to screw race assembly only.**
3. Cut verticals to size: Overall Frame Height minus 5/16" (7.9). Verticals run through. **See DETAIL C.** For cut lengths when using optional AF100 Sill Flashing cut vertical to frame height. **See DETAIL D.**
4. Cut horizontals to size: Daylight Opening. Horizontals run between verticals. Cut horizontal glazing beads 1/32" (0.8) undersize for easier installation.

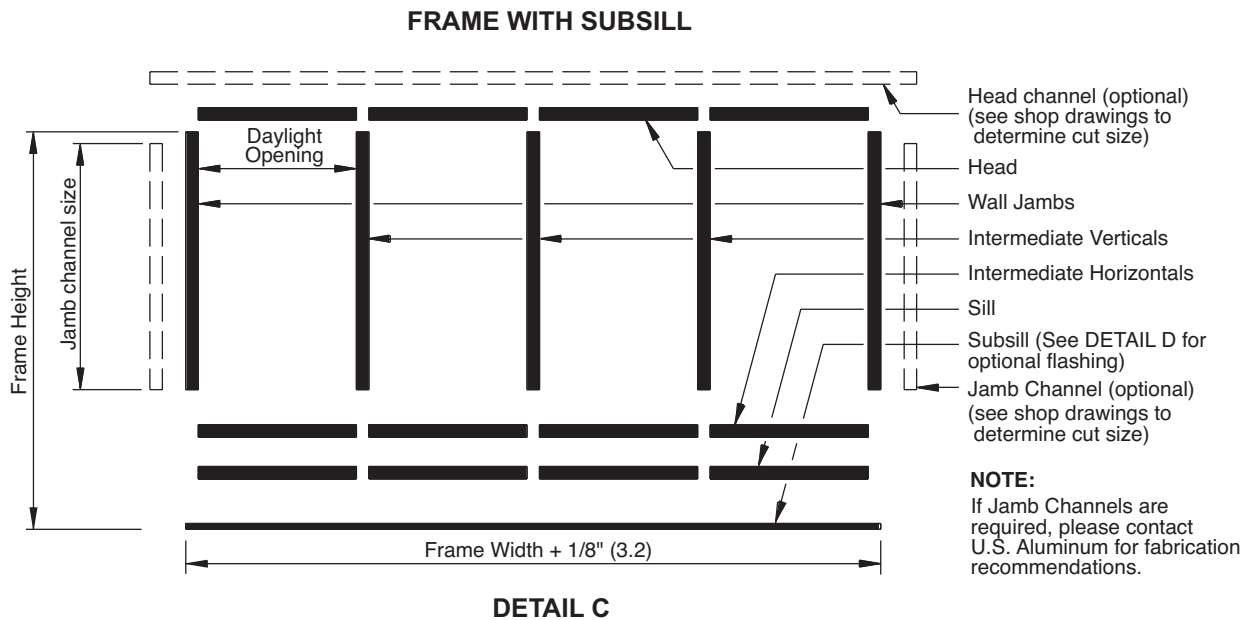

Vertical cutting lengths when using optional AF100 Sill Flashing: Cut verticals to overall frame height. **AF100 Sill Flashing thickness is not included as overall frame height.**

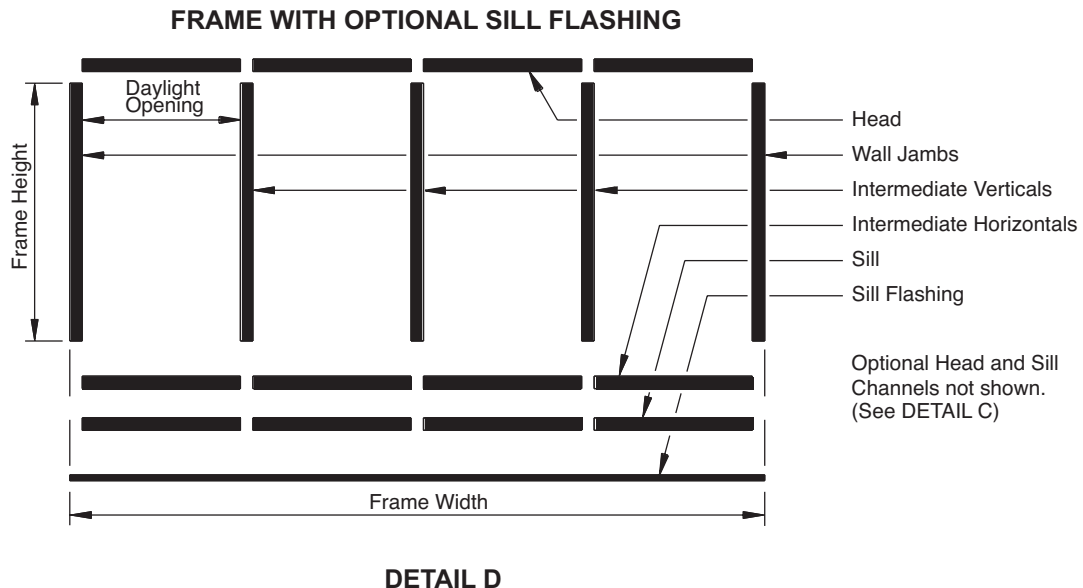

SERIES 400, 450, 451, AND IT451

5. Apply end dams to ends of subsills. See **DETAILS E through G**. Do not apply end dams to ends that butt against door jambs. See **DETAIL Z** on **PAGE 21**.

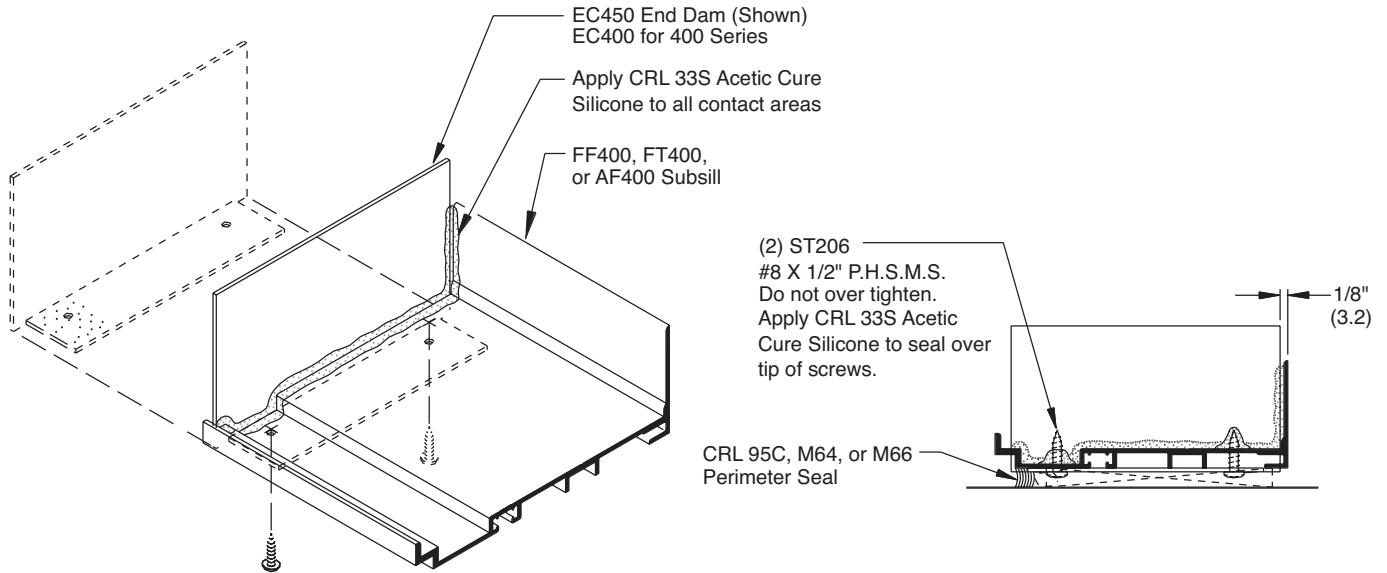

DETAIL E

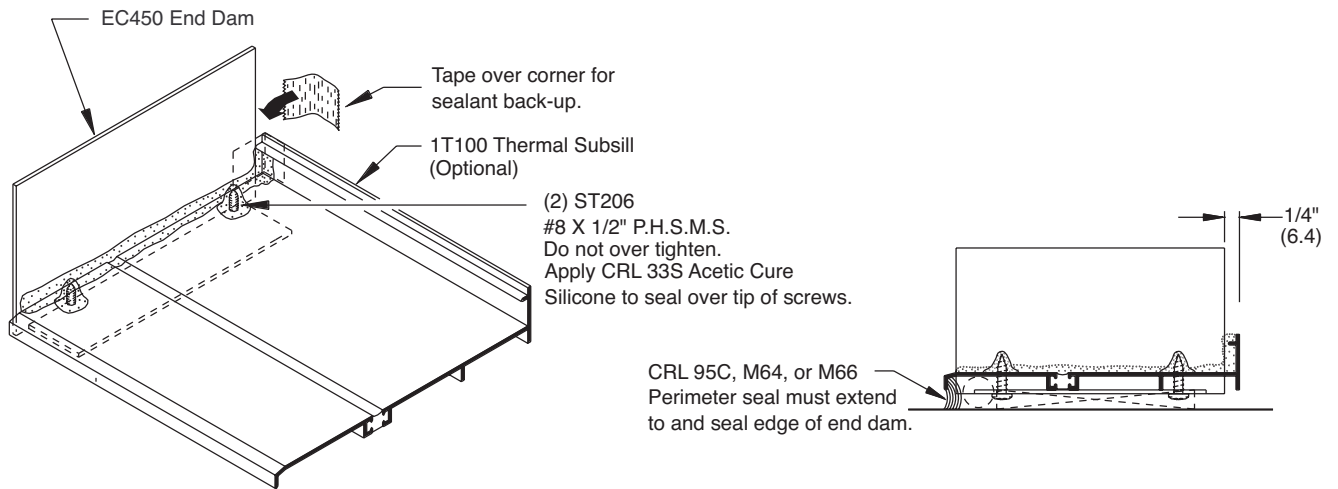

DETAIL F

NOTE: Consult Sealant Manufacturer for Proper Cleaning and Priming Recommendations

NOTE: Application and tooling of CRL 33S Acetic Cure Silicone at end dams is **CRITICAL** to prevent water penetration.

SERIES 400, 450, 451, AND IT451

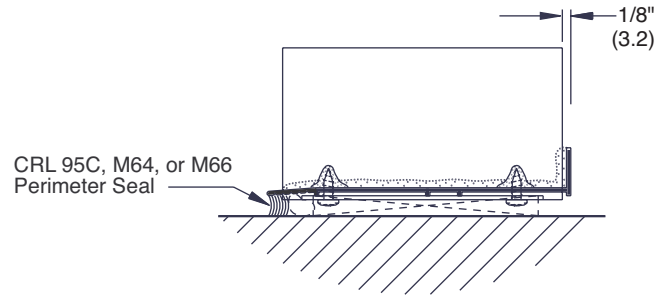
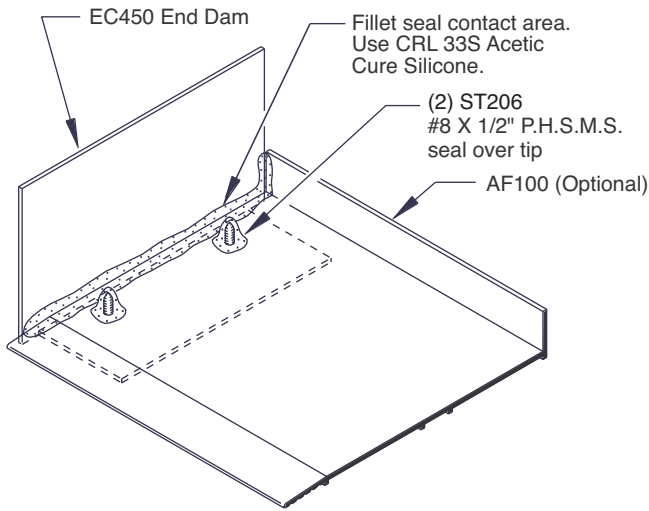

DETAIL G

6. Apply end dams to ends of head channels. See **DETAIL H**.

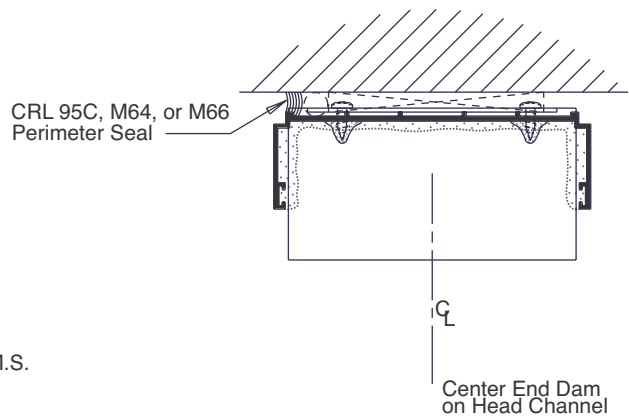
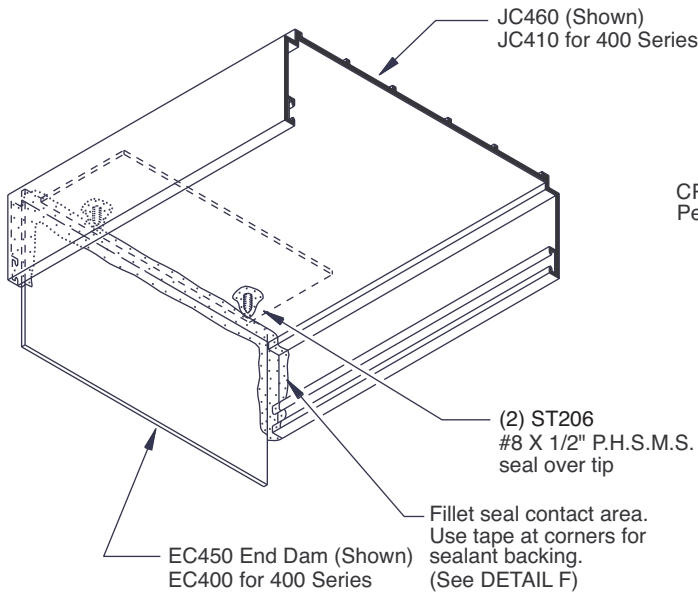

DETAIL H

NOTE: Consult Sealant Manufacturer for Proper Cleaning and Priming Recommendations

SERIES 400, 450, 451, AND IT451

- If optional head anchors are used drill 3/4" (19) dia. access holes from underside of head member 2" (51) from ends and at midpoint. See **DETAIL I**.

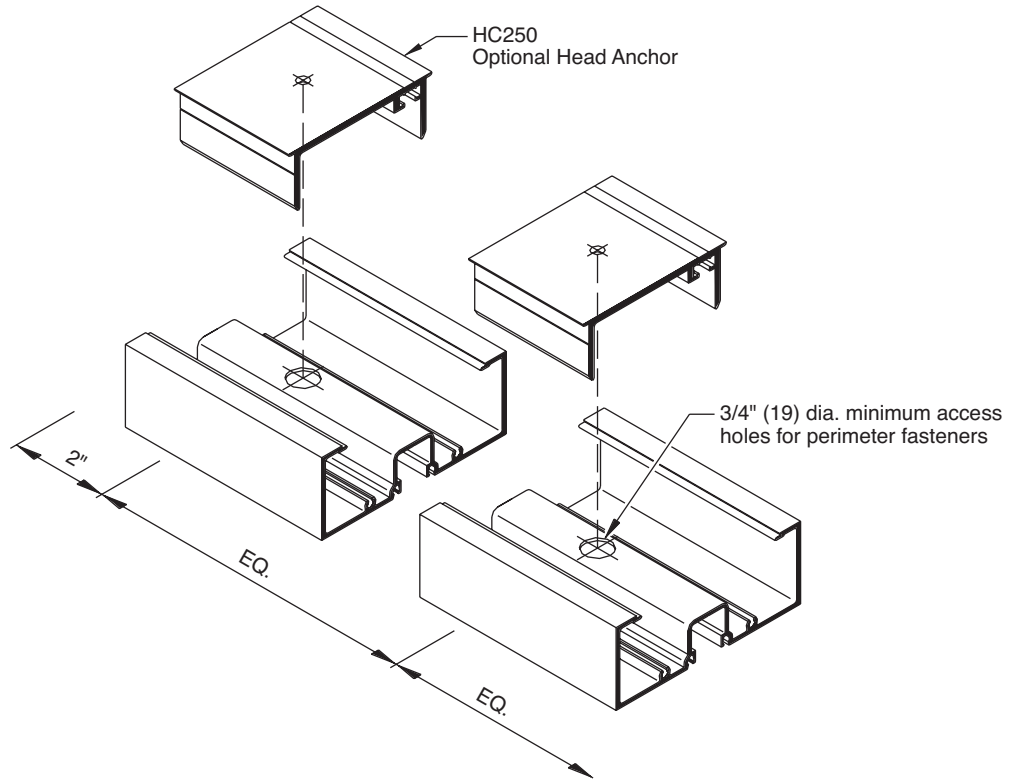

DETAIL I

DRILL JIG FABRICATION:

- Mark the location of horizontals on vertical members and drill holes for assembly screws. The use of drill jigs is recommended. See **DETAILS K through O** for hole lay-out for screw race and anchor clip applications. Place drill jig into glazing pocket as shown on **DETAIL J**. See NOTE on page 10 for helpful information.

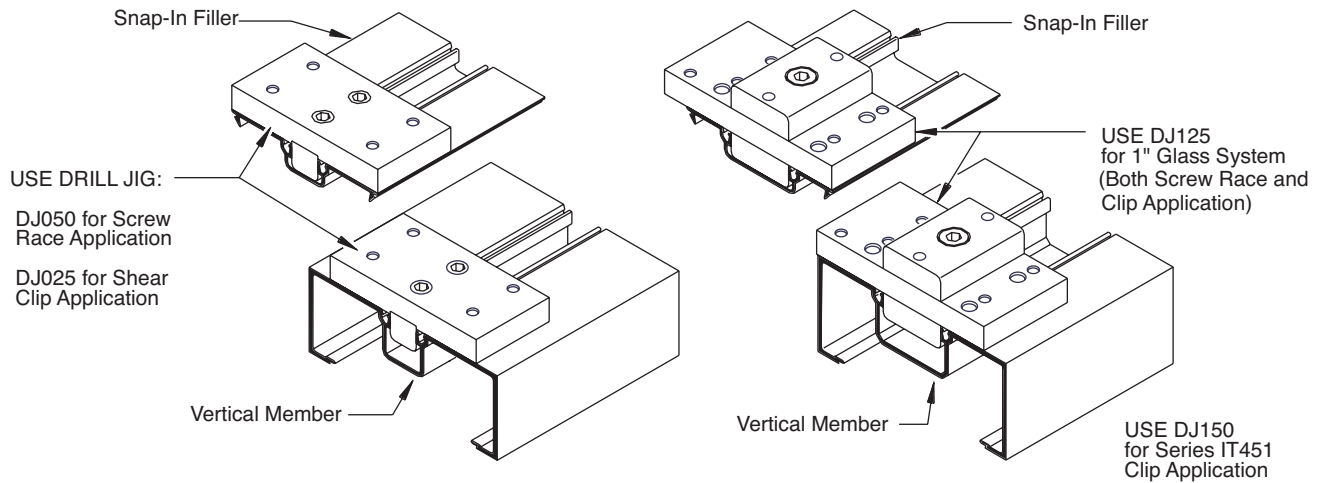

NOTE: For larger projects we offer the CRL Accufab Pro Tool visit: usalum.com for more information

DETAIL J

**SCREW RACE JOINERY
EXTERIOR GLAZING**

NOTE: Spot drill then remove Drill Jig to complete hole pattern. This will help keep bits sharp longer and reduce possibility of Drill Jig moving during drilling.

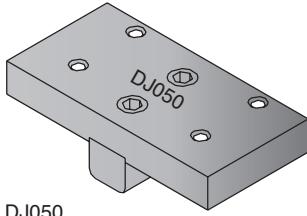

USE DRILL JIG: DJ050
For 1/4" (6) or 3/8" (10) Glazing

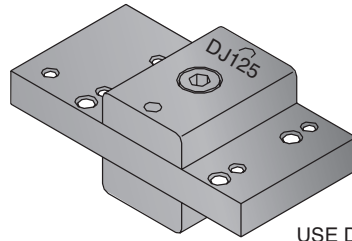

USE DRILL JIG: DJ125
For 1" (25) Glazing

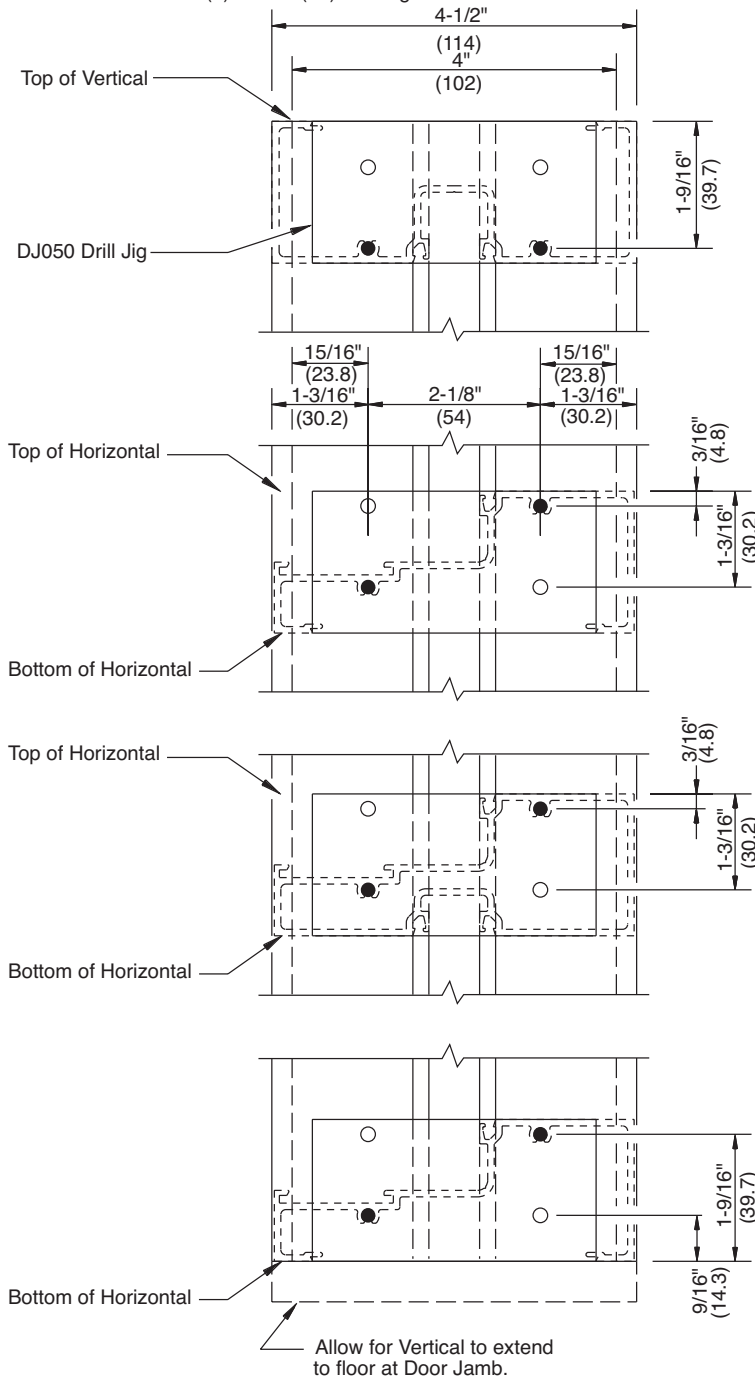

DETAIL K

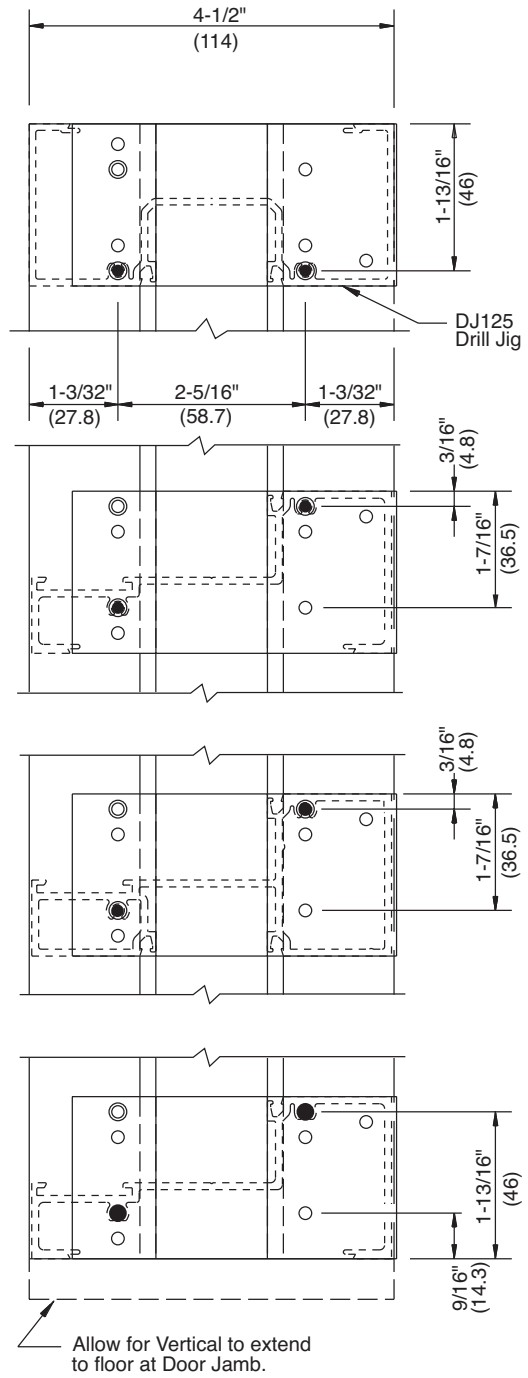

NOT TO SCALE

ANCHOR CLIP JOINERY EXTERIOR GLAZING

The last three digits of the anchor clip's part number are stamped near the corresponding guide holes on the DJ025 and DJ125 jigs. Drill Jig will need to be rotated to achieve proper hole pattern.

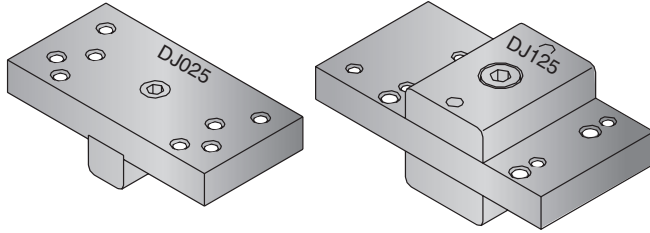

USE DRILL JIG: DJ025
For 1/4" (6) or 3/8" (10) Glazing

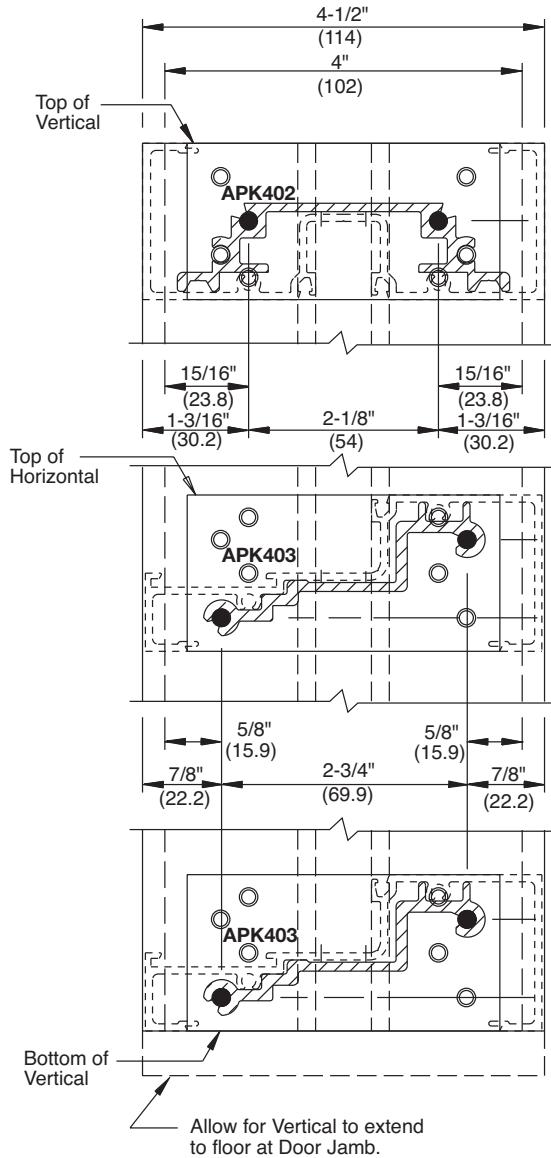

USE DRILL JIG: DJ125
For 1" (25) Glazing

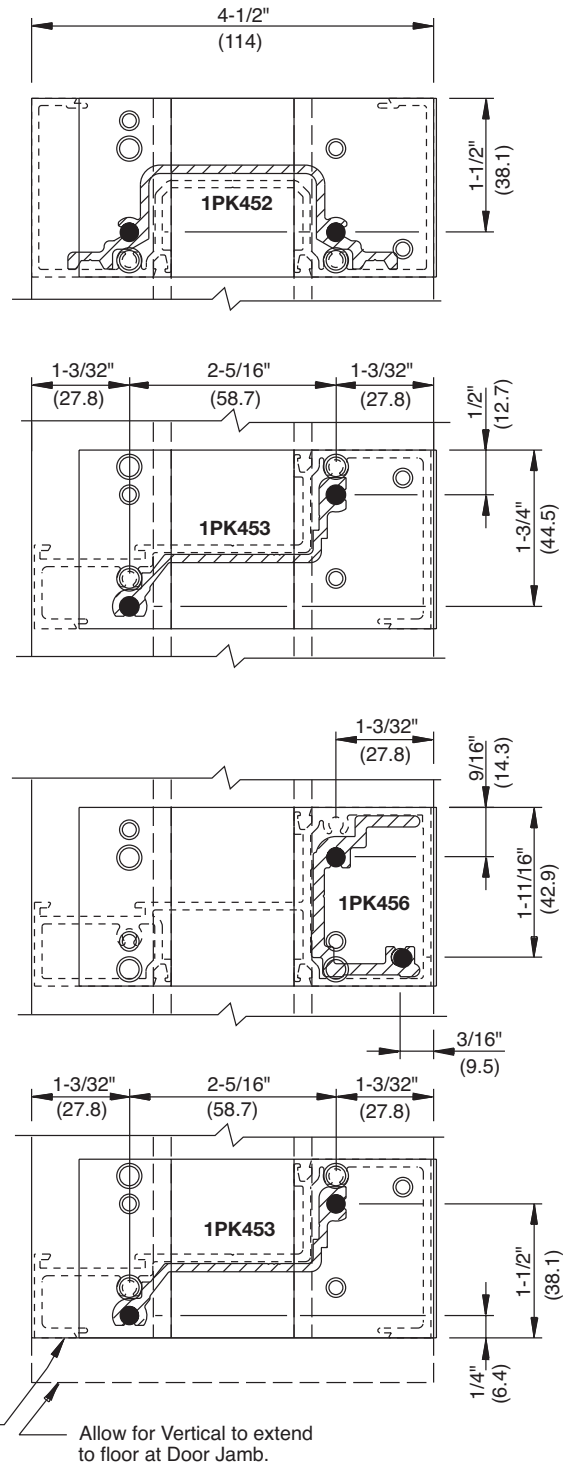

DETAIL L

NOT TO SCALE

SCREW RACE JOINERY
INTERIOR GLAZING

DJ125 NOTE: Guide Holes are marked with stamped numbers 1 through 8. See detail below for the appropriate guide marks. Drill Jig will need to be flipped to achieve proper hole pattern.

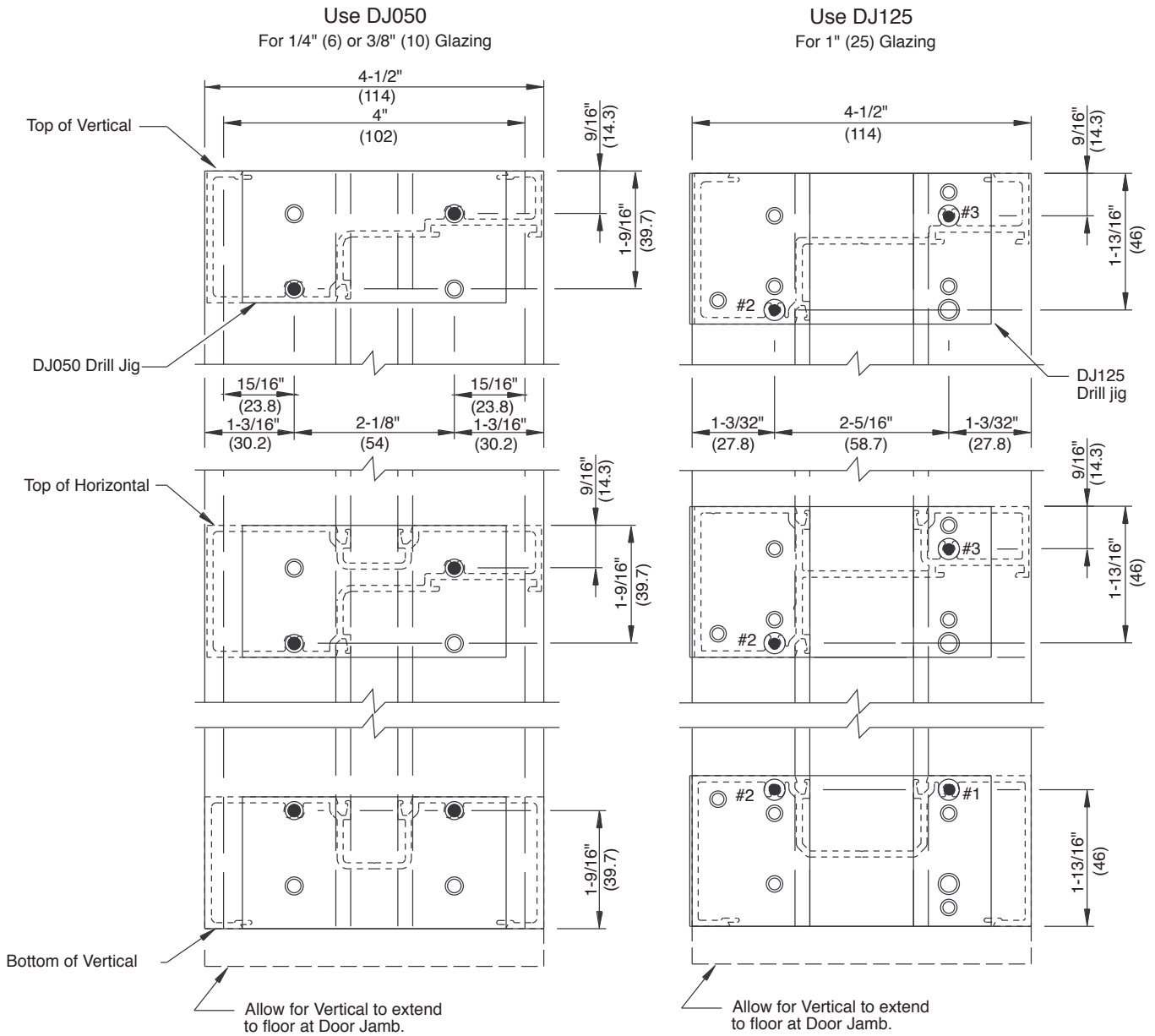

DETAIL M

NOT TO SCALE

ANCHOR CLIP JOINERY INTERIOR GLAZING

DJ025 & DJ125 NOTE: The last three digits of the anchor clip part number are stamped near the corresponding guide holes. Drill Jig will need to be rotated to achieve proper hole pattern.

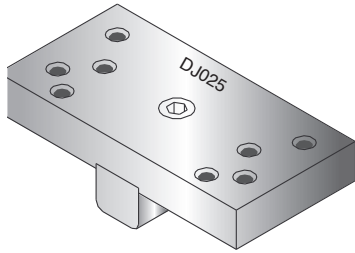

INTERIOR GLAZING

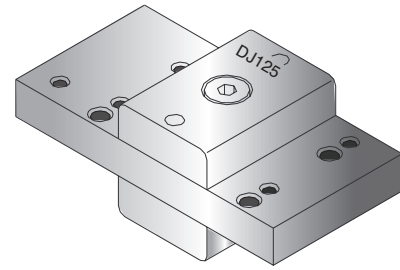

EXTERIOR GLAZING

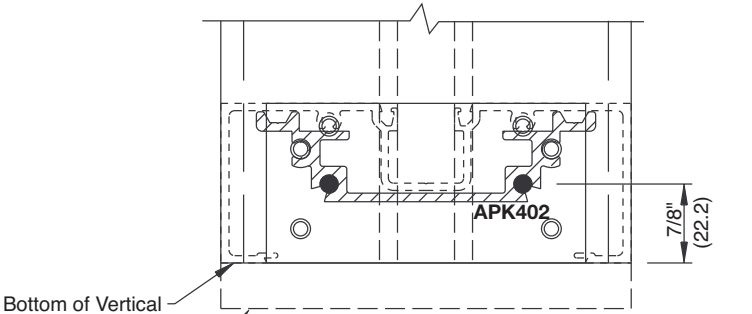
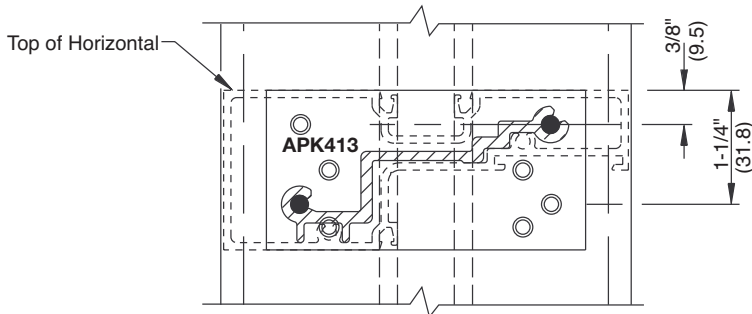
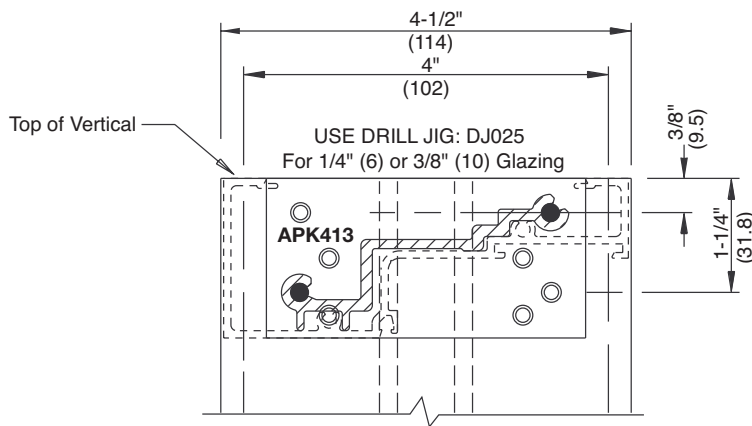

Allow for Vertical to extend to floor at Door Jamb.

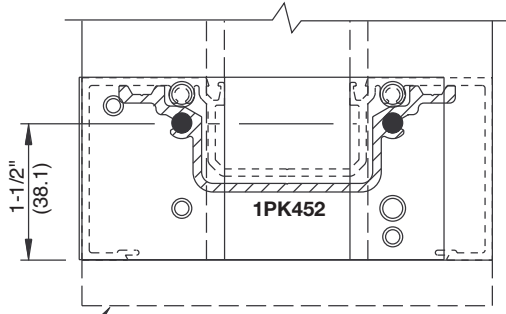
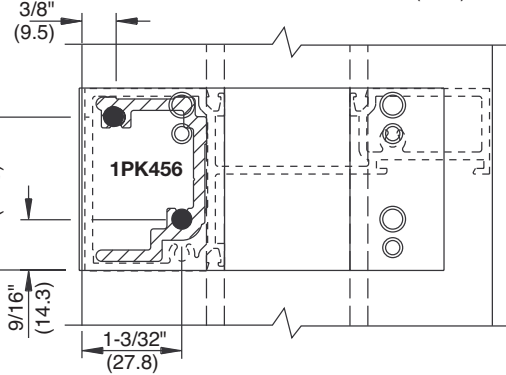
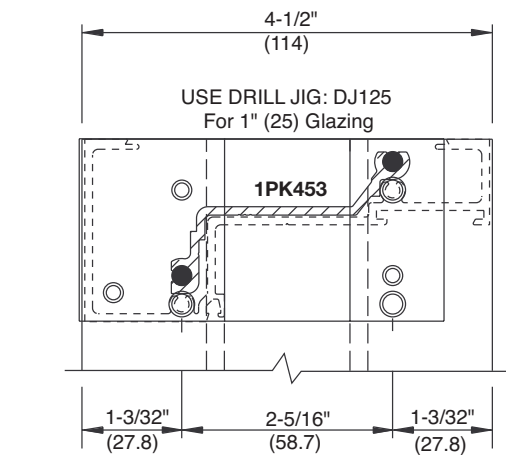

Allow for Vertical to extend to floor at Door Jamb.

DETAIL N

NOT TO SCALE

IT451 ANCHOR CLIP JOINERY
INTERIOR / EXTERIOR GLAZING

DJ150 NOTE: The last three digits of the anchor clip part number are stamped near the corresponding guide holes.

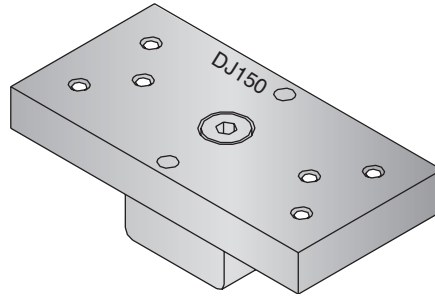

INTERIOR GLAZING

EXTERIOR GLAZING

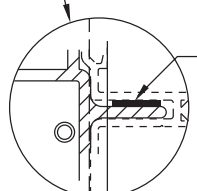
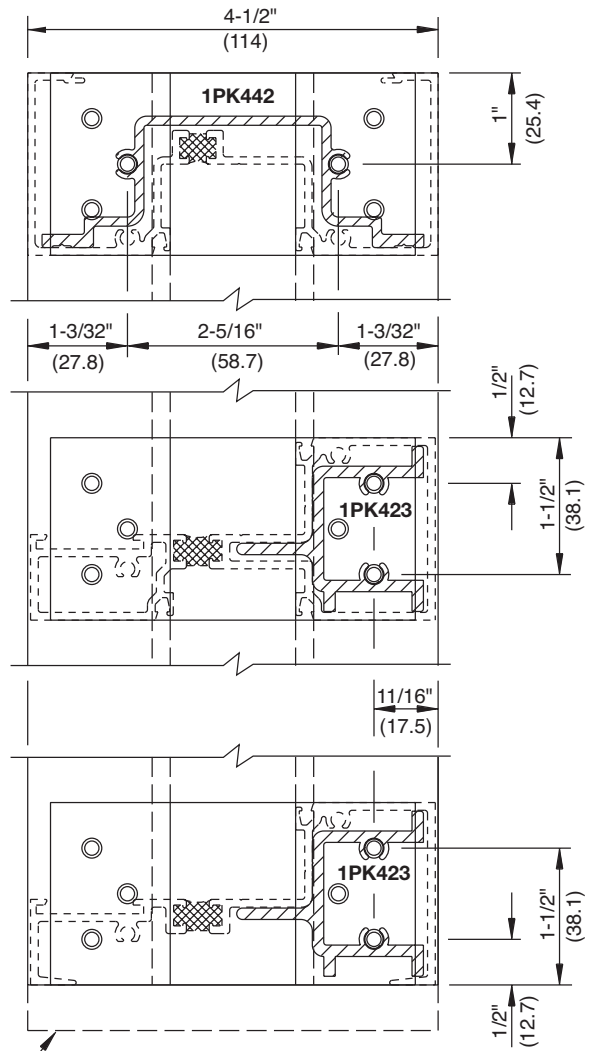
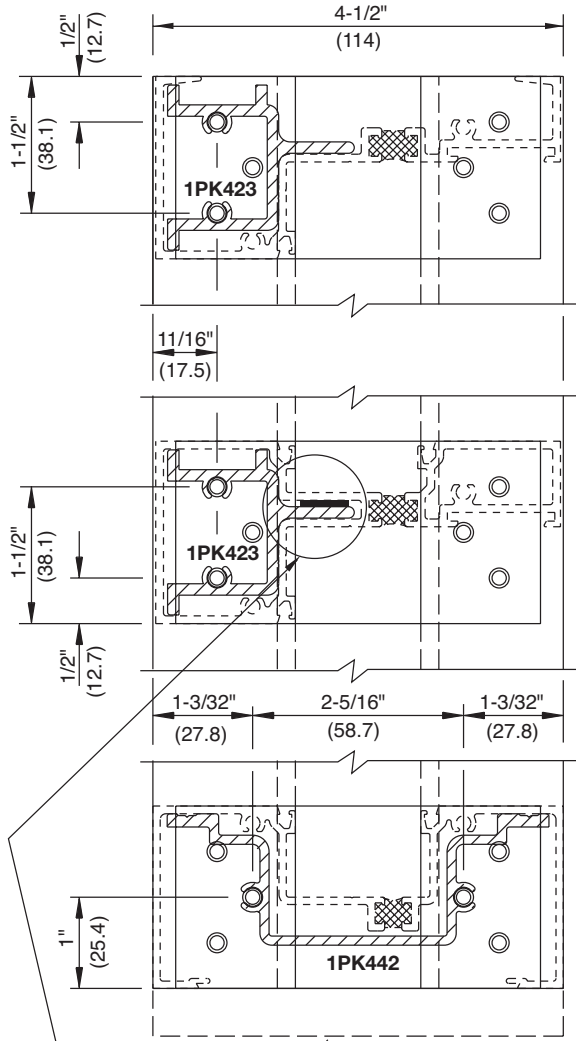

Allow for Vertical to extend to floor at Door Jamb.
Shim between Shear Block and Horizontal Member as shown

Allow for Vertical to extend to floor at Door Jamb.

DETAIL O

NOT TO SCALE

SERIES 400, 450

PICK-UP SCREWS for SERIES 400 and 450 1/4" (6) Glazing

If using horizontal anchor clips, prepare ends of intermediate horizontal members for anchor pick-up screws. Drill and Countersink for #10 X 1/2" F.H. Pick-Up Screws. **See DETAIL P.**

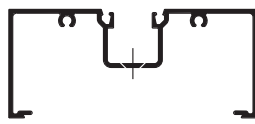
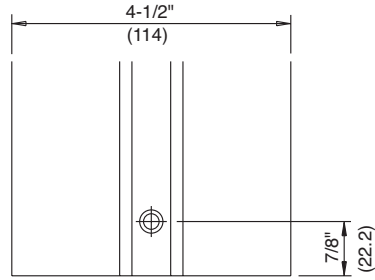
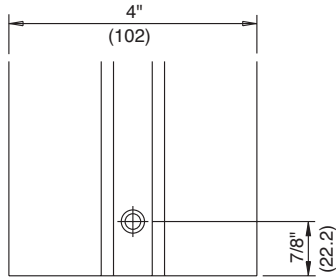

J402 / JS402

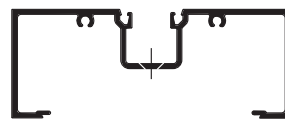

J452 / JS452

HEAD

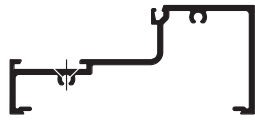
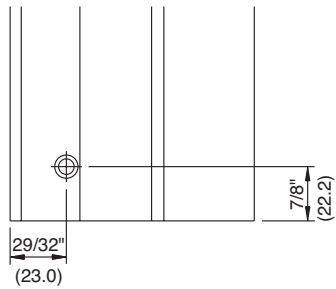

JS413

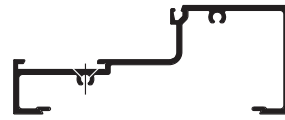
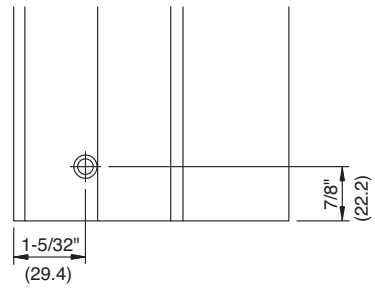

JS463

OPEN BACK
INTERMEDIATE
HORIZONTAL
AND SILL

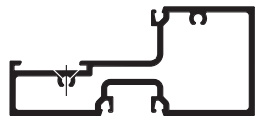
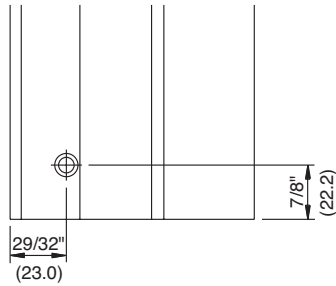

JH413

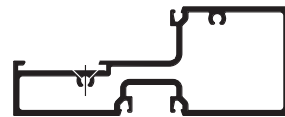
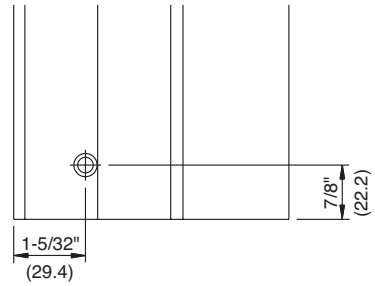

JS463

TUBULAR
INTERMEDIATE
HORIZONTAL

DETAIL P

NOT TO SCALE

SERIES 451, IT451

PICK-UP SCREWS for SERIES 451 and IT451 1" (25) Glazing

If using horizontal anchor clips, prepare ends of intermediate horizontal members for anchor pick-up screws. See **DETAIL Q** for screw type and length for each member.

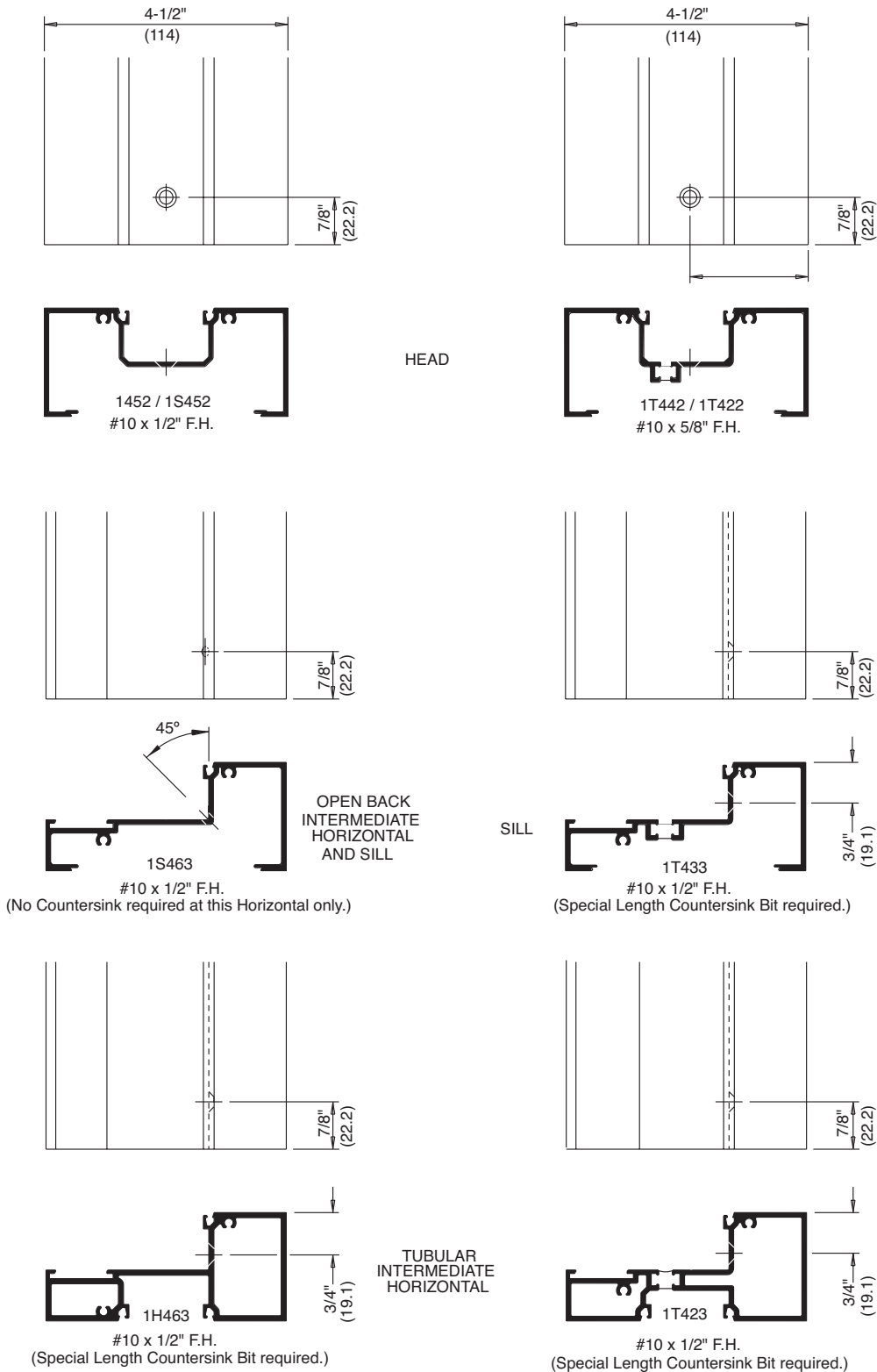

NOT TO SCALE

SERIES 400, 450, 451, AND IT451

9. If transition adaptors for 1/4" (6.4) spandrel are being used (Series 451 and IT451) **see DETAIL MM on page 27.**
10. Apply CRL RTV408 silicone to edge of all horizontal members and assemble panels using screws provided. **See DETAIL R.** Never allow two shallow pockets to face each other. Tool excess silicone. Refer to pages 16 and 17 for pick up screw prep locations.

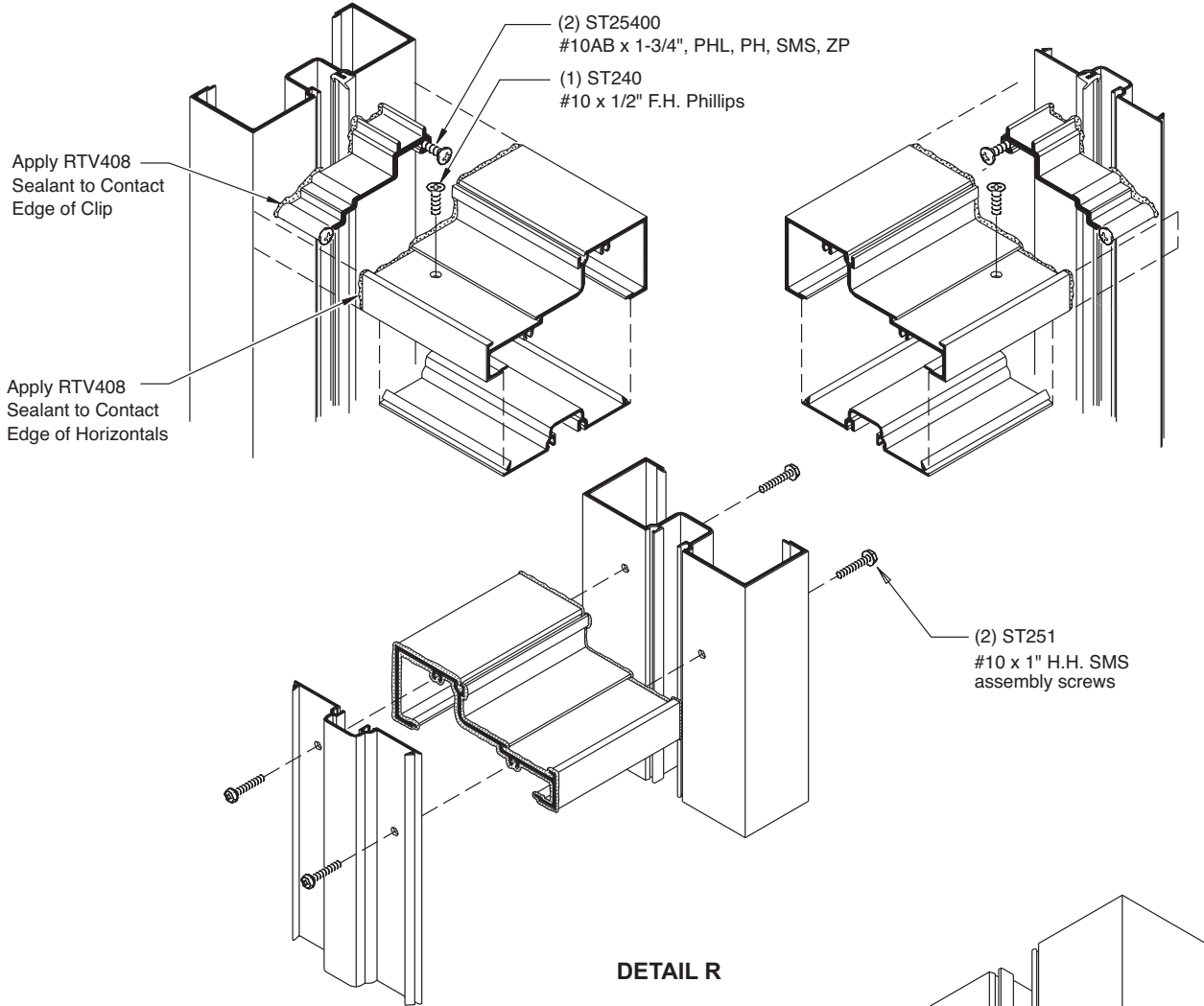

After Panels are assembled, apply and tool a bead of silicone to joint between verticals and sill members from underside, to ensure a water tight installation. **See DETAIL S.**

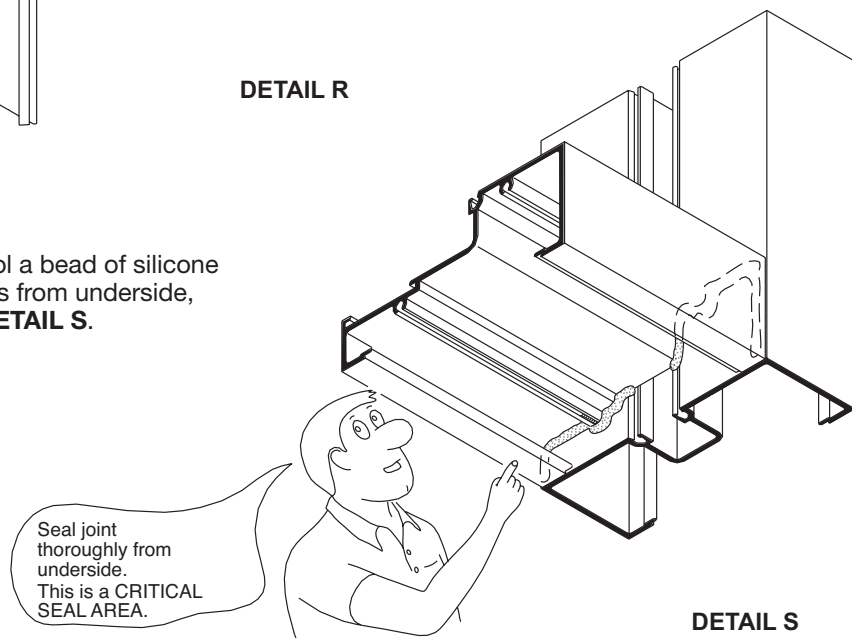

11. Apply jamb filler to back of wall jamb. See **DETAIL T**.

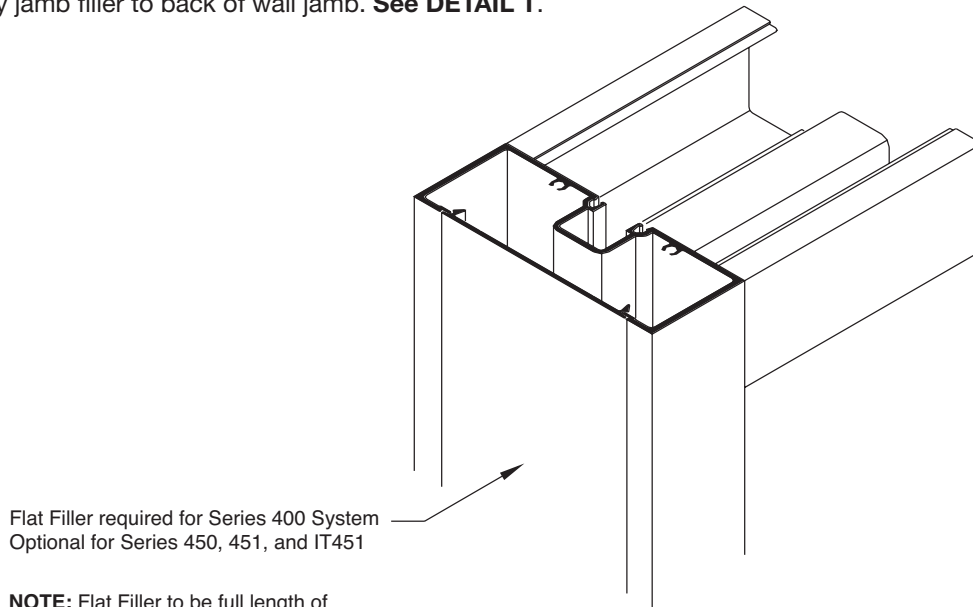

Flat Filler required for Series 400 System
Optional for Series 450, 451, and IT451

NOTE: Flat Filler to be full length of
Jambs at Series 400. If used at 4-1/2"
(114) Depth Systems, Cut 6" (152.4)
long. Place at centers of Jamb Anchors.

DETAIL T

12. Apply CRL RTV408 silicone to top edge of vertical and header member. See **DETAIL U**. Insert closure plates. Closure plates will need to be modified to fit with some vertical members. See page 19 **DETAIL W**. Closure plates are required to ensure continuous perimeter sealing.

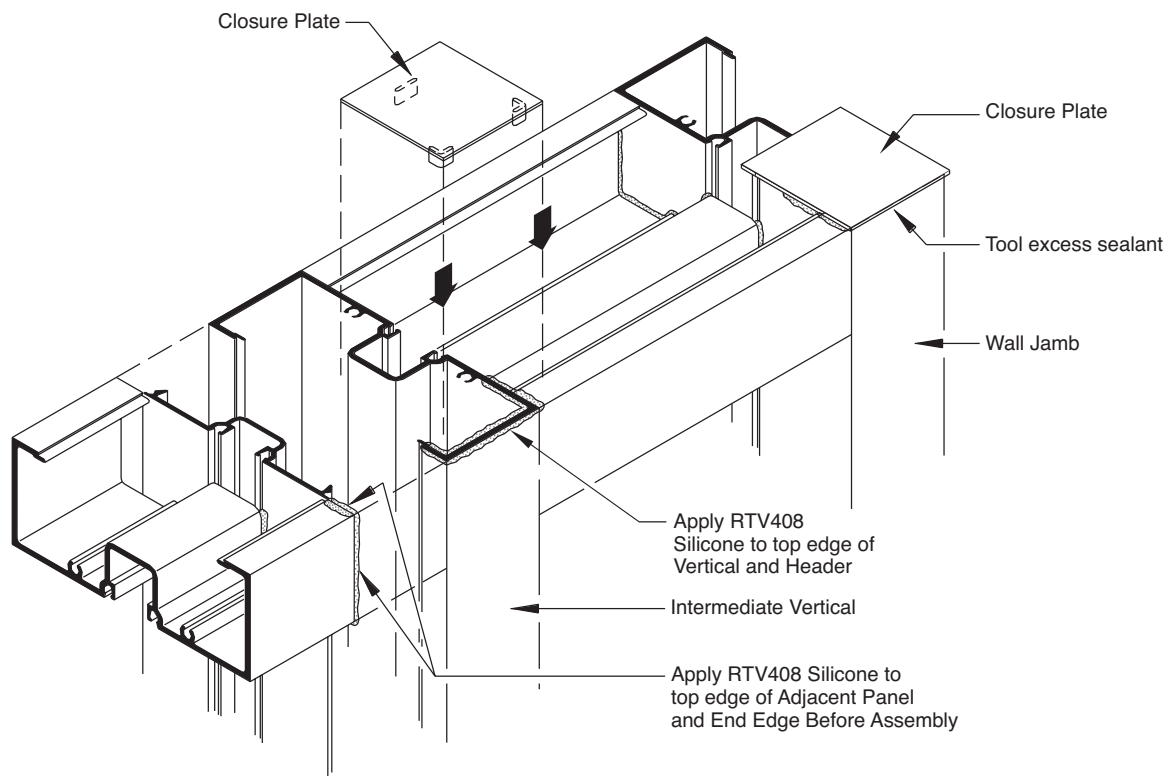

DETAIL U

SERIES 400, 450, 451, AND IT451

With some applications end dams require tab removal. **See DETAIL V and W** below to determine which tabs to remove. (Tabs shown hatched are the tabs to remove)

NOTE: Tabs should be cut-off flush with flat surface to assure proper fit at ends of vertical mullions.

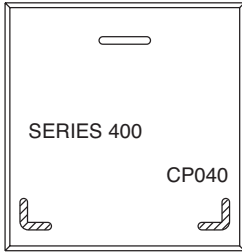

Use at: JS410 and JS419
Expansion Mullion
See DETAIL W below.

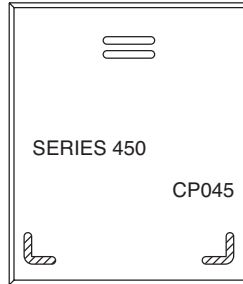

Use at: JS460 and JS469
Expansion Mullion
See DETAIL W below.

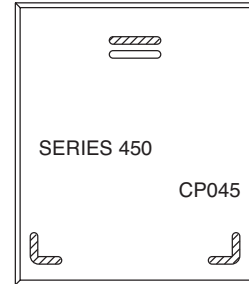

Use at: JH475
DURA FRONT Mullion

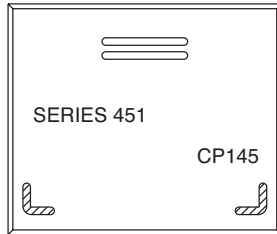

Use at: 1S470, 1S479, 1T470 and 1T479
Expansion Mullion
See DETAIL W Below.

1S431 and 1S531
Heavy Wall Mullions

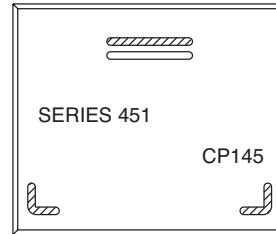

Use at: 1S471
Door Jamb Mullion
1H475
DURA FRONT Mullion

DETAIL V

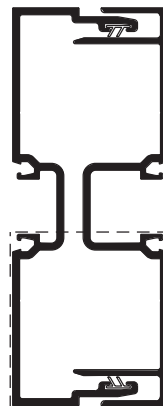

NOTE: Consult factory for sealing at Expansion Mullions.

END CAP INSTALLATION
AT EXPANSION MULLIONS
SERIES 400, 450, 451 & IT451

DETAIL W

13. If head anchors are used tape them to header members at clearance hole locations. **See DETAIL X.**

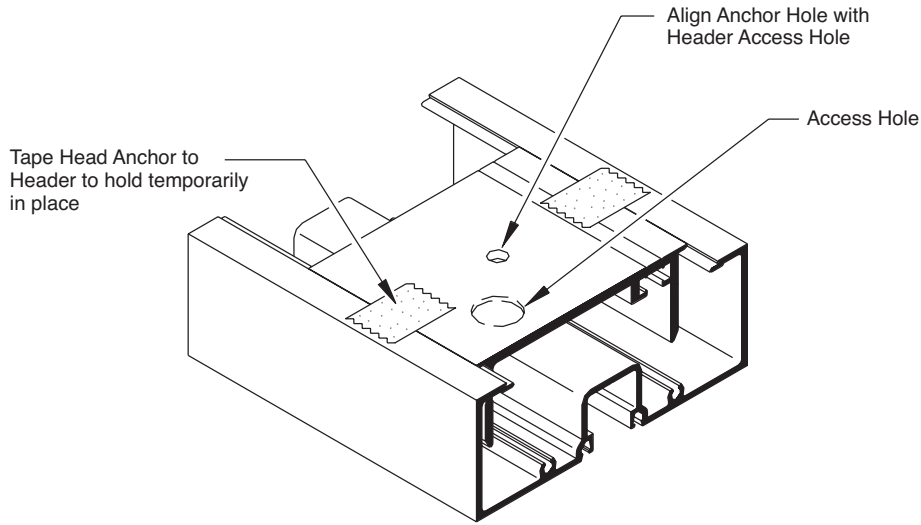

DETAIL X

When Entrances occur install Entrance Frames first. See Entrance Doors and Frame Installation Instructions.

14. Set subsill into place, shimmed as required for leveling, and anchor to structure. Locate fasteners 6" (152) each side of vertical and 24" (610) on center or as required. Holes for fasteners should be elongated laterally to allow for thermal movement. Pin subsill to structure at one point only per cut length. **NOTE:** See shop drawings for proper location of pinned connections. For corners **See DETAIL NN on PAGE 28.** Subsill should be shimmed at fastener locations, underneath verticals and at setting block locations. Seal all joints and over heads of fasteners. **See DETAIL Y.**

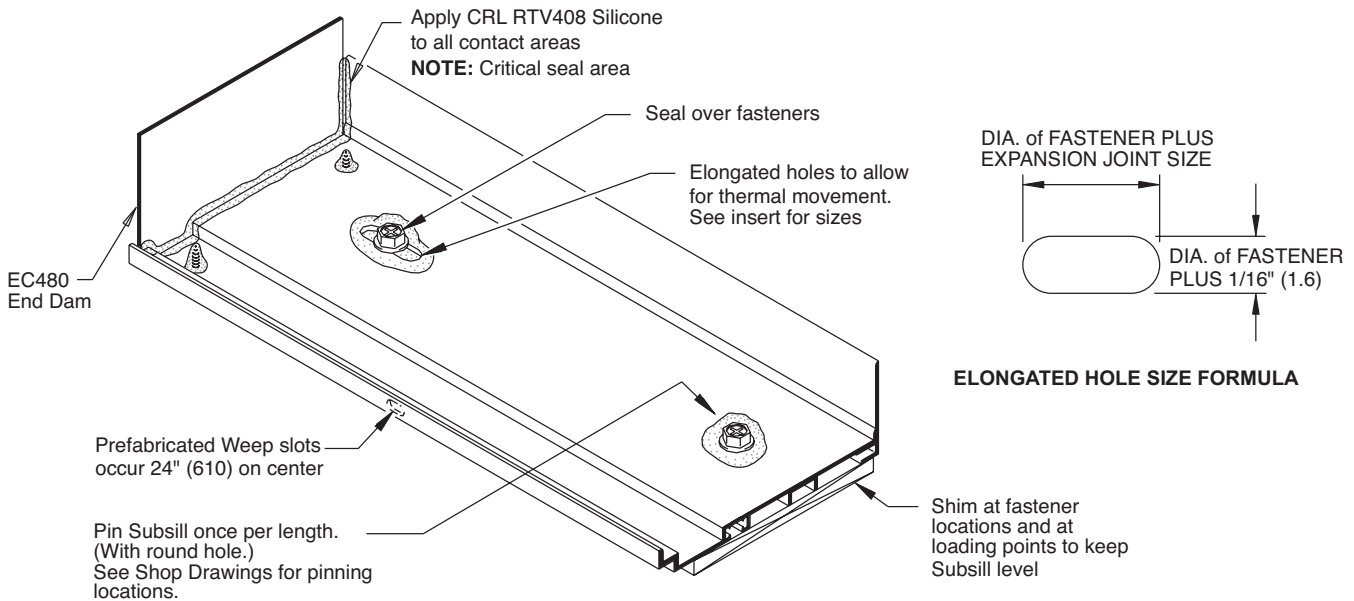

DETAIL Y

NOTE: Consult Sealant Manufacturer for Proper Cleaning and Priming Recommendations

NOT TO SCALE

SERIES 400, 450, 451, AND IT451

Subsill butts against door jambs, where they occur.

NOTE: End of subsill that butts against door jamb cannot be dammed. Special care should be taken to control water infiltration at this point. **See DETAIL Z.** Infiltrated water from upper lights must be kept out of jambs.

See NOTE on page 23, step 19.

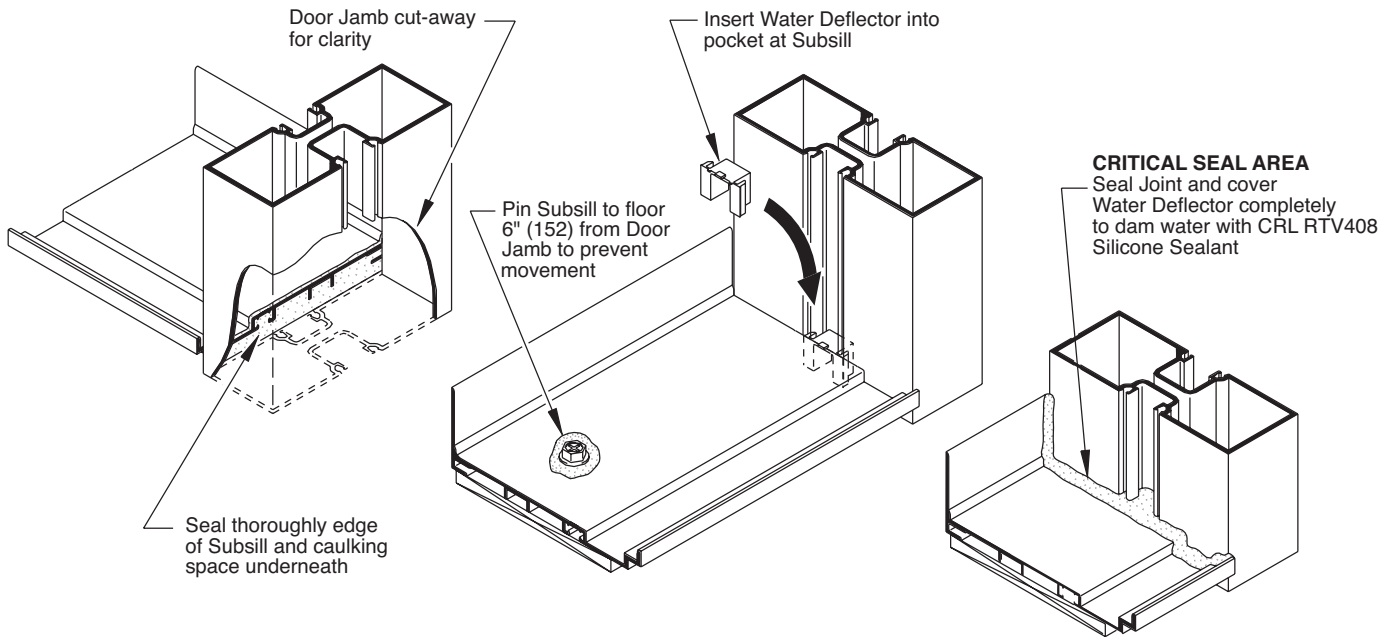

DETAIL Z

15. Splice as required. Splice sleeves are required at splice joints. **See DETAIL AA.** Follow similar method when using 1T100 and AF100 subsills.

NOTE: Consult Sealant Manufacturer for Proper Cleaning and Priming Recommendations

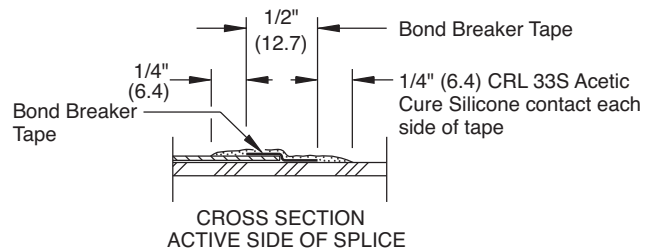

Splice Sleeve
Seal with CRL 33S Acetic Cure Silicone All Joints

To ensure a proper two-way bond apply CRL 827T1 Bond Breaker Tape to outside of the Splice Sleeve before installation so the sealant can be "buttered" over the joint and properly expand and contract.

For active side of Splice, apply Bond Breaker Tape CRL 827T38 and Cover with CRL 33S Acetic Cure Silicone. (See Cross Section Above)

A minimum of 1/2" (12.7) Expansion Joint required every 24' (7.3 m)

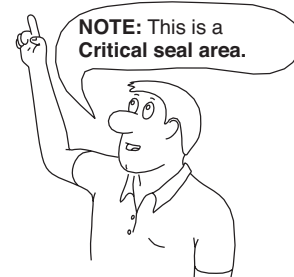

DETAIL AA

NOT TO SCALE

SERIES 400, 450, 451, AND IT451

16. If there are no entrances, start frame installation at wall jamb unit. Apply CRL RTV408 silicone to end dam contact areas. **See DETAIL BB.**

Set first panel interior subsill into place.

NOTE: Temporarily shim behind end dam to push it tight against wall jamb. **See DETAIL BB.** Panel must be pushed against subsill upturned back wall. **See DETAIL GG, page 24.** Plumb and shim unit and fasten it to structure. Locate header fasteners 6" (152) each side of verticals and no more than 24" (610) on center. (**See DETAIL CC** for optional head anchor). Secure wall jamb through glass pocket as required to limit deflection. Always shim at anchor points.

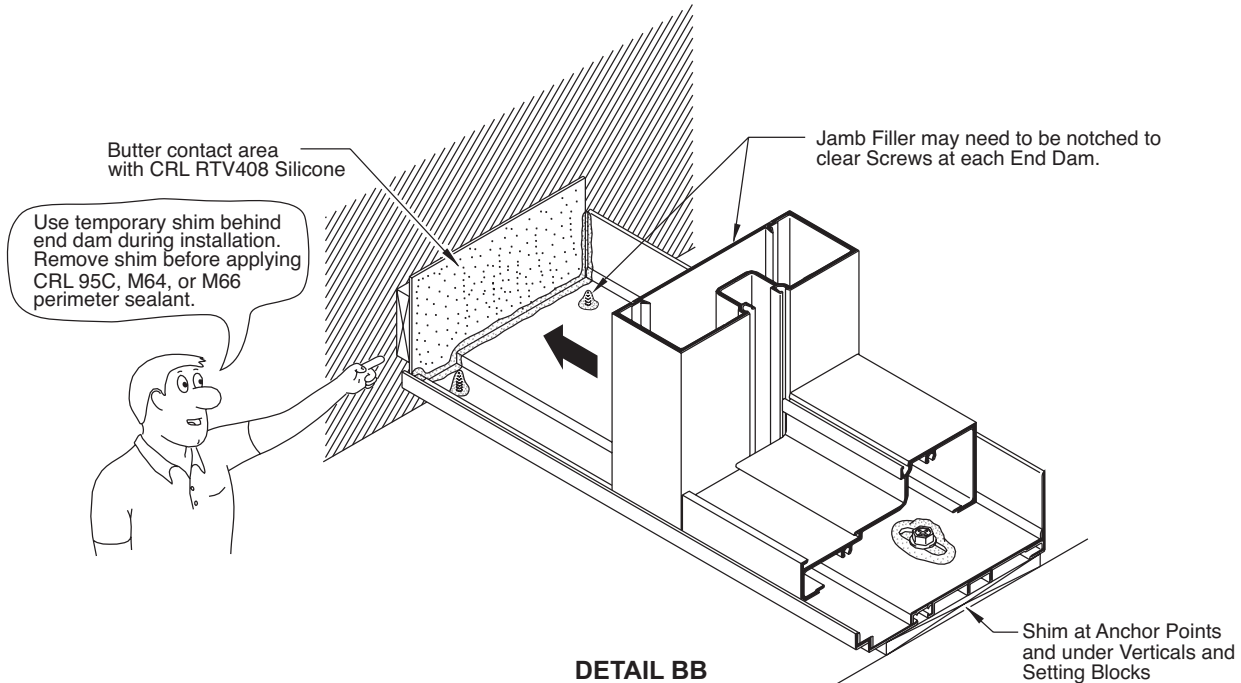

17. If optional head anchors are used, fasten them to structure through head member access holes.

NOTE: Top of header must align with line mark in head anchors for optimum performance.

Anchors may be shimmed if required. **See DETAIL CC.**

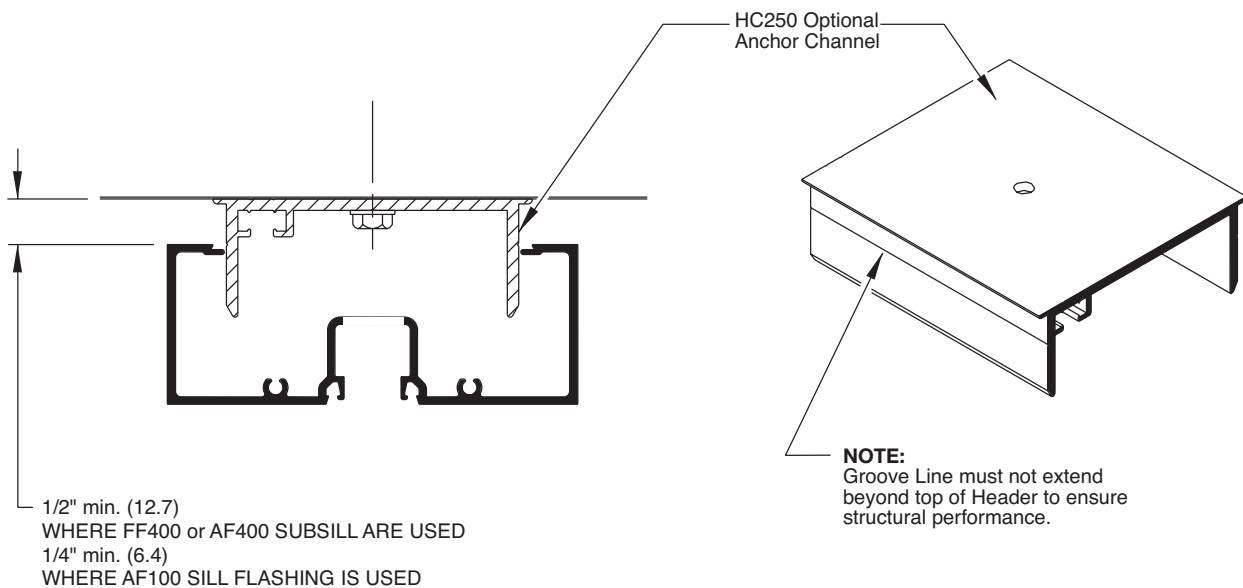

18. Install remainder of panels, one by one, snapping them together. **See DETAIL DD.**

NOTE: The last two panels may require to be installed together as a unit to fit into opening. **See Detail A, page 5.**

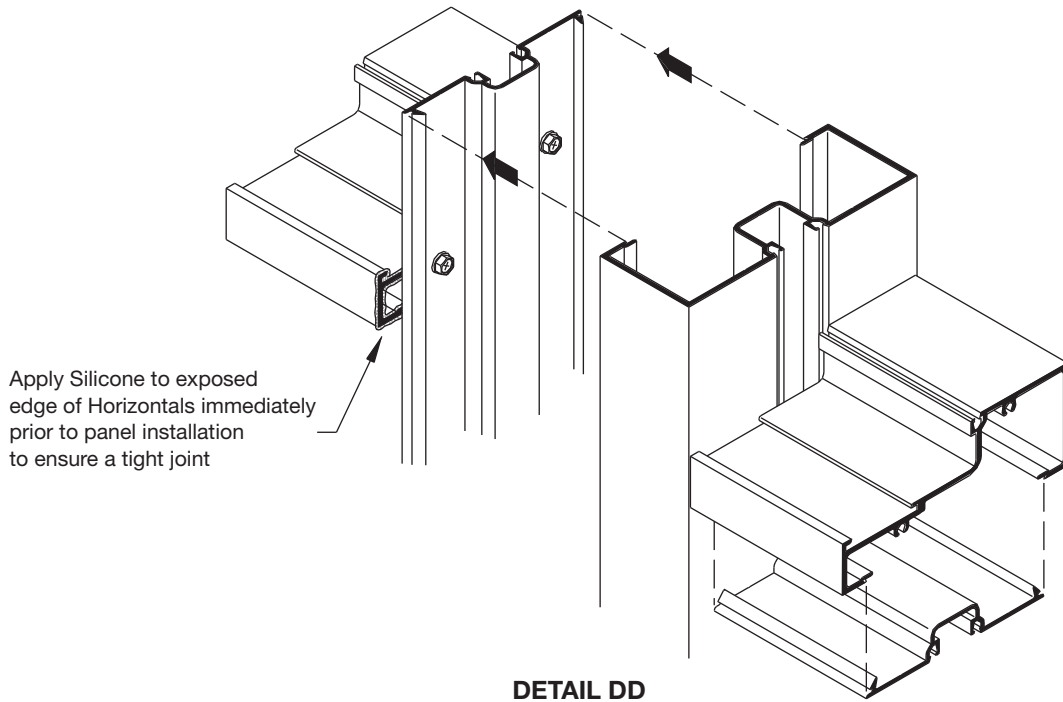

DETAIL DD

19. Apply CRL RTV408 Silicone to vertical glazing pocket and gasket reglet at vertical/horizontal intersection. Silicone must be applied to two sides of pocket, only clearance at exterior will allow infiltrated water to run down to subsill. **See DETAIL EE** below and **DETAIL FF on page 24.**

Insert water deflector into glazing pocket and slide it down to position. **See DETAIL EE.** Top of deflector must be flush with horizontal glazing pocket.

NOTE: Water deflectors at door jamb must be sealed all around to prevent water from running to floor (water will drain to other end).

NOTE: THERMAL CENTER GLAZE (IT451)

Apply Bond Breaker Tape and seal over slots of 1X200 filler to allow for sealing at water deflector locations.

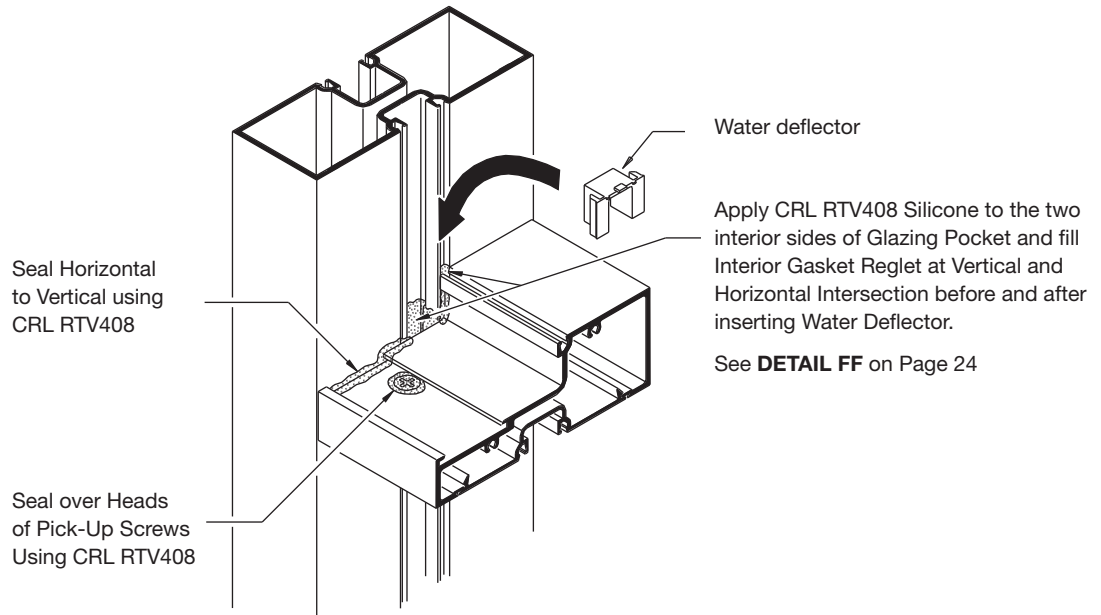

DETAIL EE

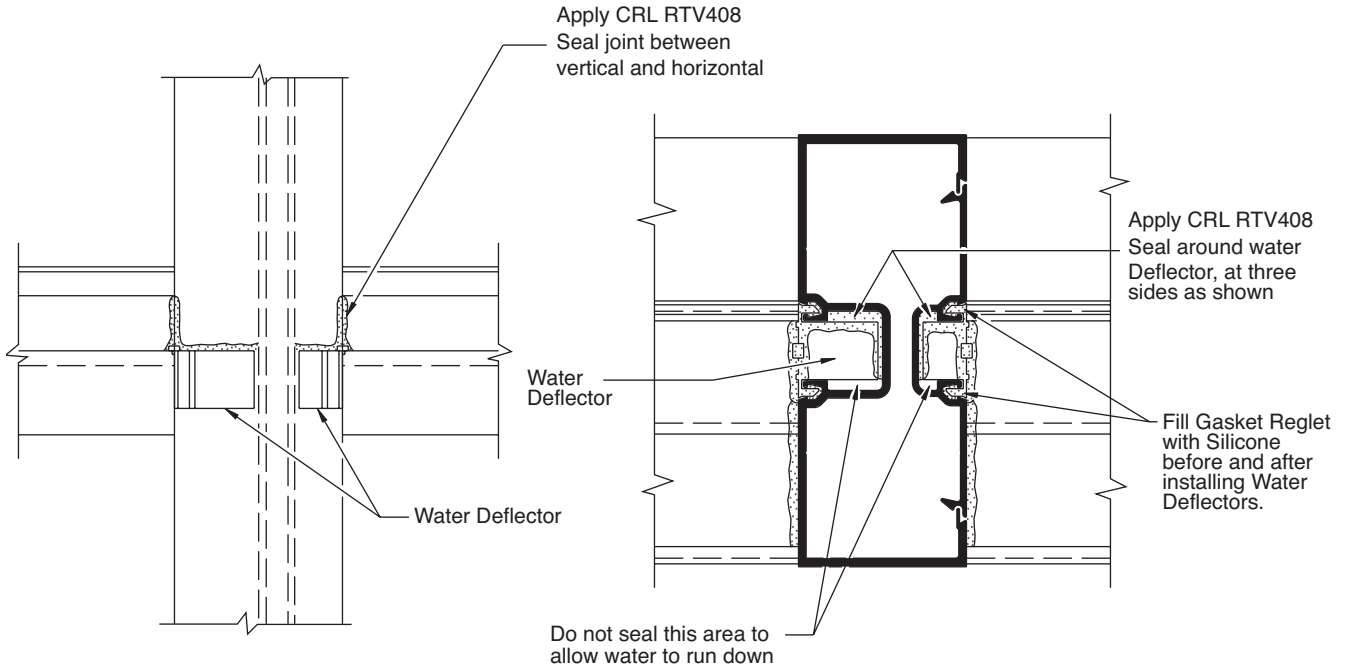

DETAIL FF

20. Apply CRL RTV408 to seal joints between panels and subsill at both interior and exterior. See **DETAIL GG**.

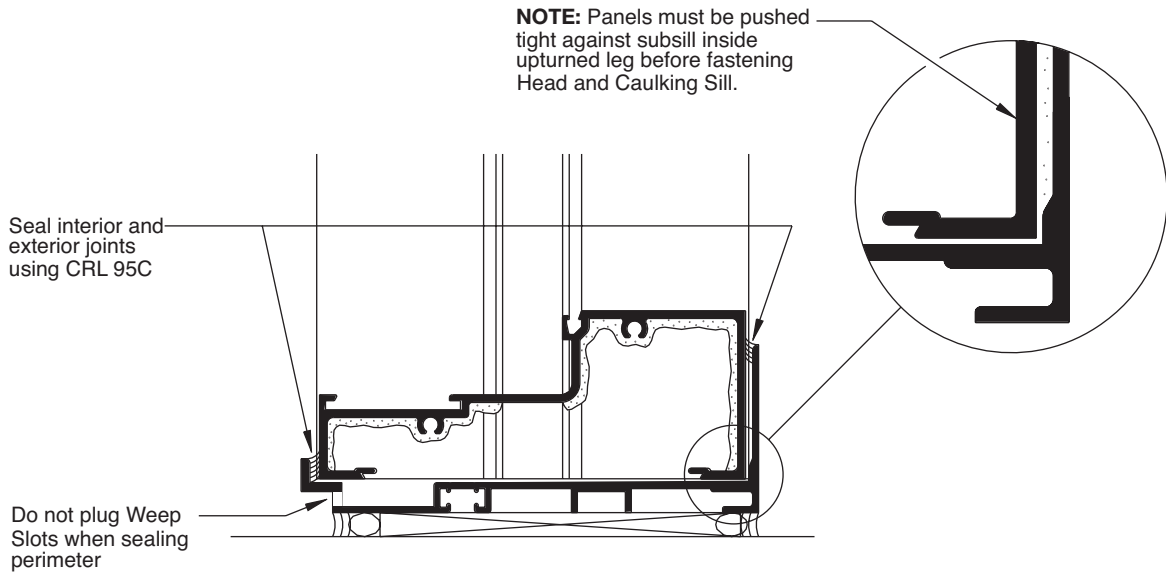

DETAIL GG

21. When interior glazing a multistory building, exterior perimeter sealing must be done before glazing unless perimeter seal is to be applied from the exterior as a secondary operation.

GLAZING

Glass Sizes*:

Series 400 and 450 for 1/4" (6.4) Glass:

Daylight Opening + 5/8" (15.9)

Series 451 and 451 for 1" (25) Glass:

Daylight Opening + 7/8" (22.2)

*These formulae do not account for glass tolerances. Consult glass manufacturer before ordering glass. See Door Frame instructions for glass size at transom.

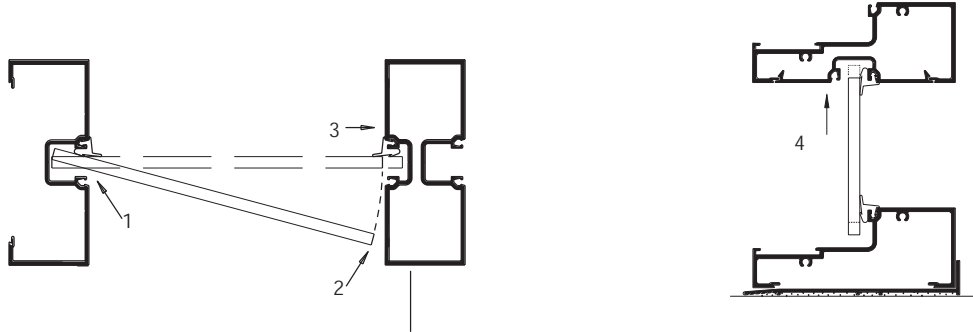

DETAIL HH

EXTERIOR GLAZING

1. Cut glazing gaskets to size. Gaskets should be 1/8" (3.2) longer per foot of aluminum member to allow for shrinkage. Same gaskets are used at interior and exterior.
2. Install interior gasket. Vertical gasket runs through. Start at corners and work towards center. Tight-butted corners are critical to avoid leakage. Seal ends of horizontal gaskets prior to abutting to vertical gaskets.
3. Set glass in place following the four step procedure. **See DETAIL HH.** Be careful not to disturb interior gasket while installing glass. Center glass in the opening.
4. Locate setting blocks in horizontal/sill member. Check deadload charts and shop drawings for correct setting block locations. Rest glass on setting blocks pressed against installed gaskets.
5. Snap-in glazing beads. **See DETAIL II.**
6. To prevent glass from shifting in the opening, one "W" side block should be installed into deep glass pocket of the vertical at center point or as recommended by glass manufacturer. **See DETAIL LL on page 27.**



DETAIL II

INTERIOR GLAZING

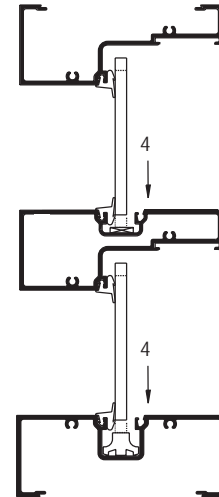
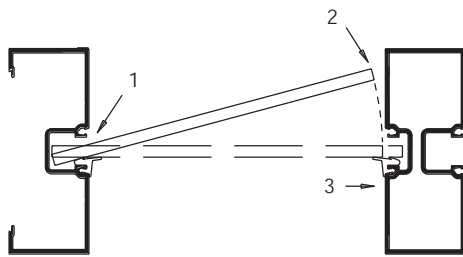

DETAIL JJ

1. Cut glazing gaskets to size. Gaskets should be 1/8" (3.2) longer per foot of aluminum member to allow for shrinkage. Same gaskets are used at interior and exterior.
2. Insert setting blocks, two per glass light, into horizontal and sill members. Check deadload charts and shop drawings for correct setting block locations.
3. Install exterior gaskets. Vertical gaskets run through. Start at corners and work towards center. Tight butt joined corners are critical to avoid leakage. Seal ends of horizontal gaskets prior to butting to vertical gaskets.
4. Set glass in place following the four step procedure. **See DETAIL JJ.** Be careful not to disturb exterior gasket while installing glass. Center glass into opening and rest on setting blocks pressed against exterior gasket.
5. Snap-in glazing beads. **See DETAIL KK.**

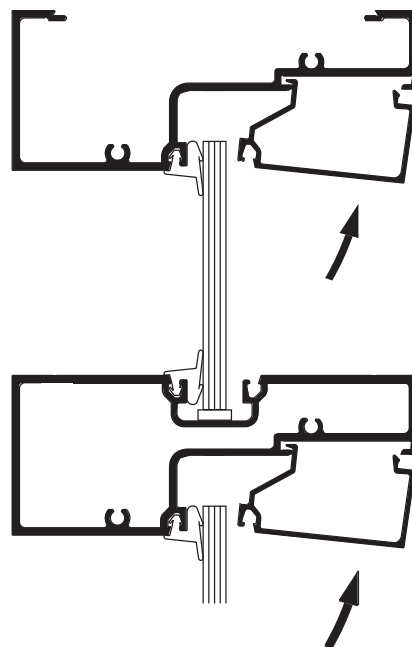

DETAIL KK

SERIES 400, 450, 451, AND IT451

6. To prevent glass from shifting in the opening one "W" side block should be installed into deep glass pocket of the vertical at center point or as recommended by glass manufacturer. Side blocking is recommended to prevent glass from shifting in pocket. **See DETAIL LL.**

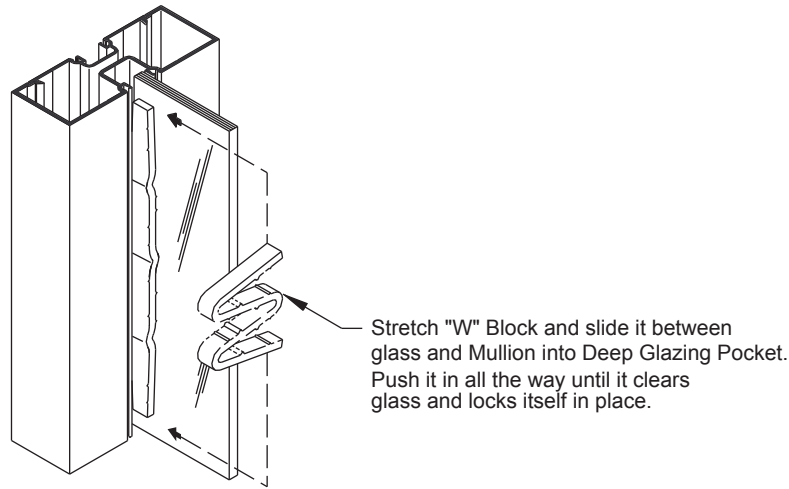

DETAIL LL

7. Install remaining gaskets. Vertical gaskets run through. Start at corners and work toward center. Tight butt joined corners are critical to avoid leakage. Seal ends of horizontal gaskets prior to abutting to vertical gaskets.

TRANSITION GLAZING

Transition adaptors for 1/4" (6.4) spandrel are supplied as required. Adaptors are cut Daylight Opening (DLO) minus 1/32" (0.8). Run continuous bead of silicone sealant into reglet and install adaptors. **See DETAIL MM.**

NOTE: Always install water deflector before rolling in adaptors. Use deflectors for 1" (25) glazing.

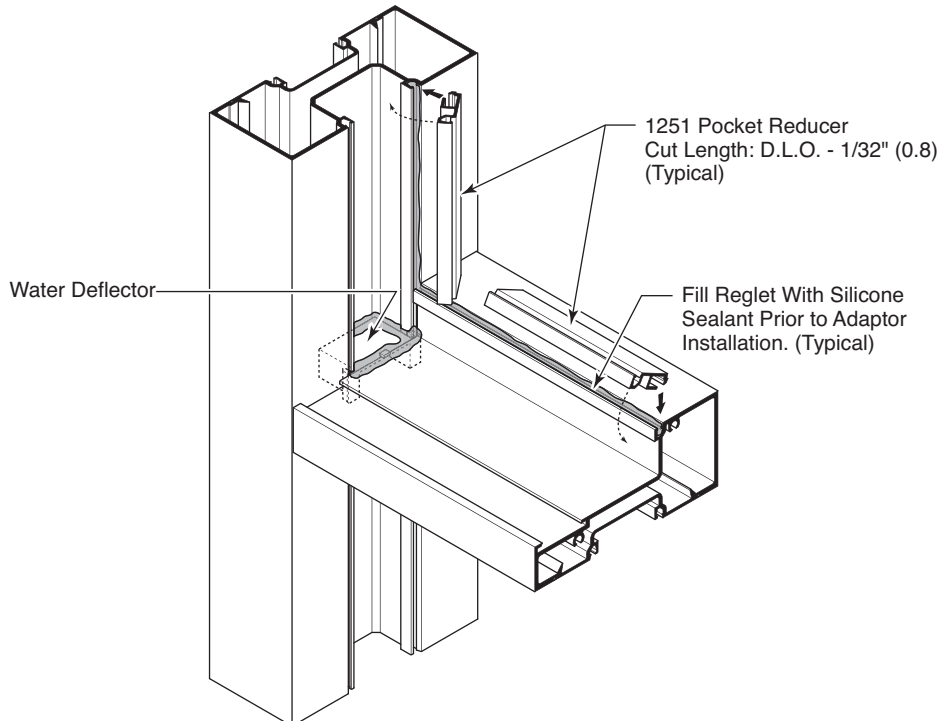

DETAIL MM

CORNER CONDITIONS

NOTE: Due to varying field conditions at corner elevations, please consult factory for proper anchoring and splicing.

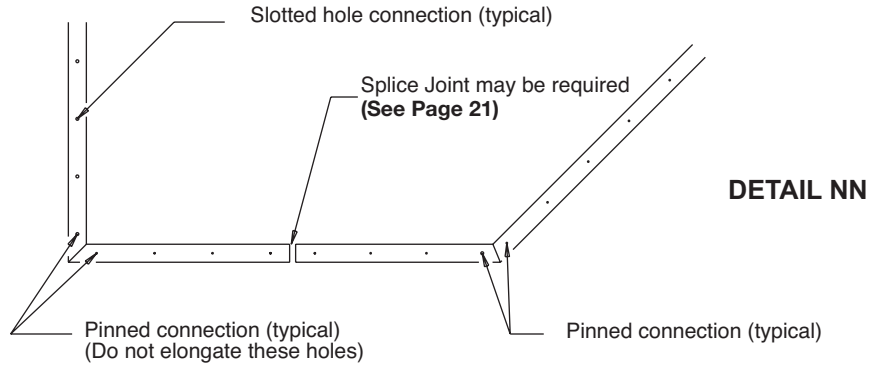

The Series 400 and 450 two-piece 90° corner posts for 1/4" (6) glass may be assembled to horizontals using either screw race or anchor clip attachment. **See DETAIL PP on page 29.**

The Series 451 and IT451 two-piece 90° corner posts for 1" (25) glass requires anchor clip assembly. **See DETAIL OO.**

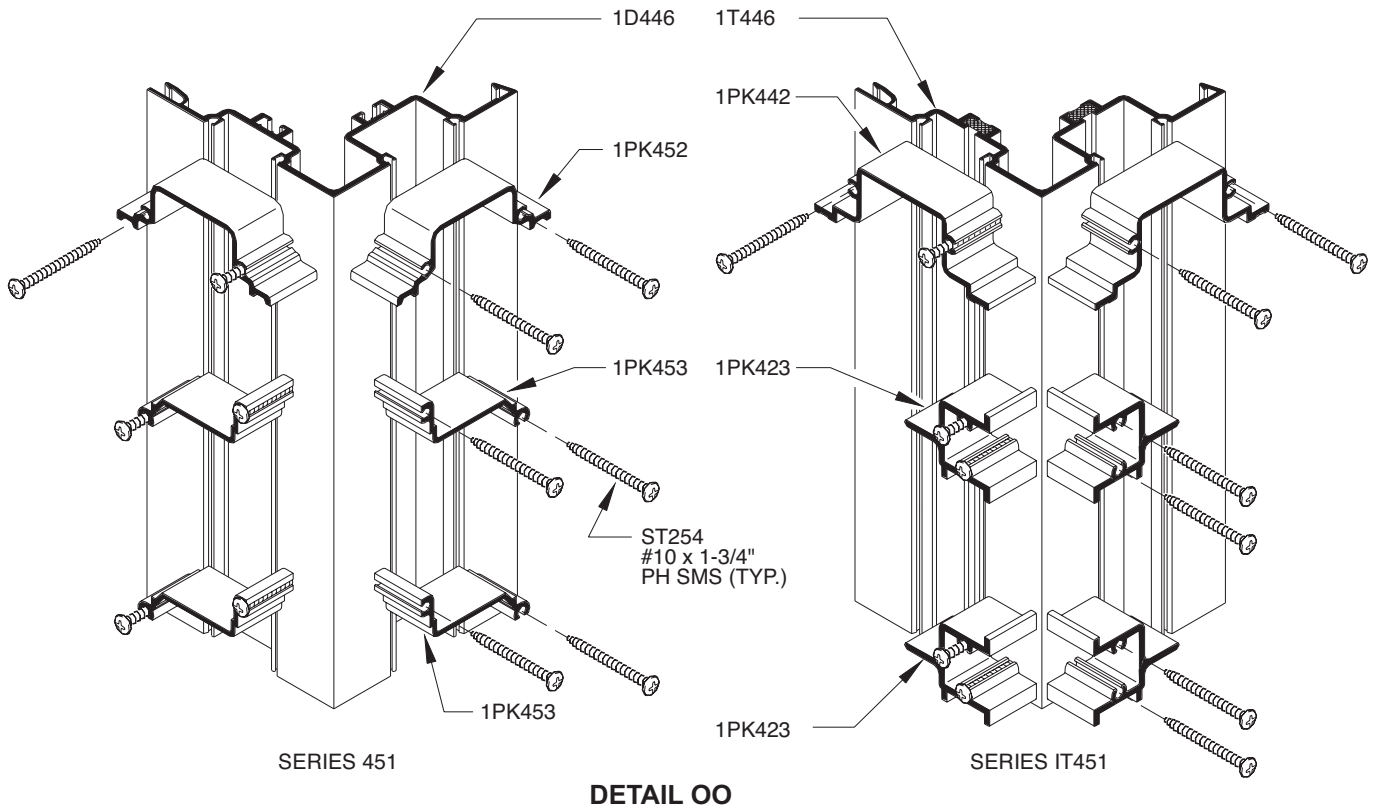

NOTE: 1D446 and 1T446 have one Shallow Pocket. Plan frame accordingly. NEVER allow two Shallow Pockets to face each other.

90° CORNER

1. Install mitered subsill on one side of corner first. Secure it to structure. Install adjoining subsill to form corner as required. Secure it to structure, and seal over all fasteners. Apply bond breaker tape along full depth of miter joint and seal joint with silicone.
2. Set corner left panel ending with JD454 (JD404/1D446/1T446) first. Attach horizontals of right panel to right side of corner. **See DETAIL PP.** Re-seal any damaged sealant at mitered joint of subsill.
3. The corner trim can be installed anytime after right panel is completed. Corner trim should be lifted over exterior lip of subsill base before snapping into place. **See DETAIL QQ.**
Refer to **DETAIL OO** on page 28 for 1" (25) insulated glass clip application.

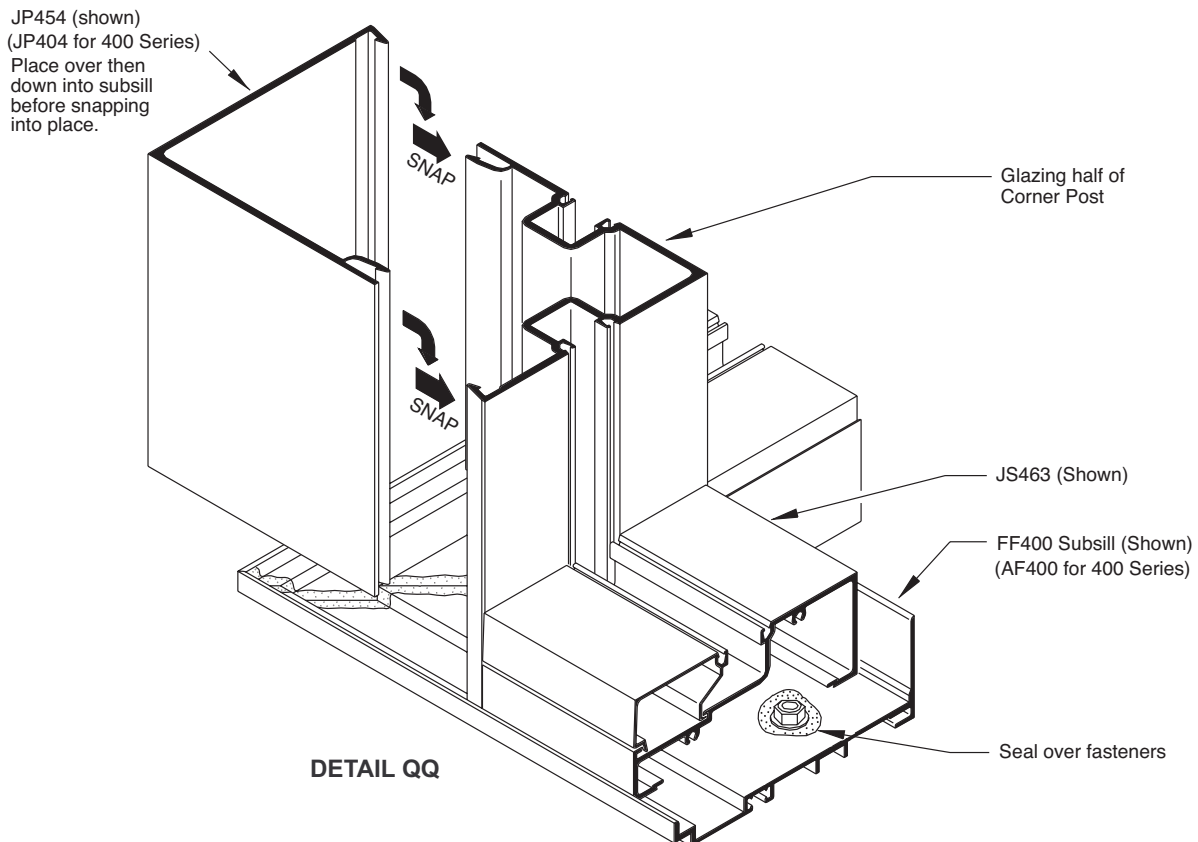
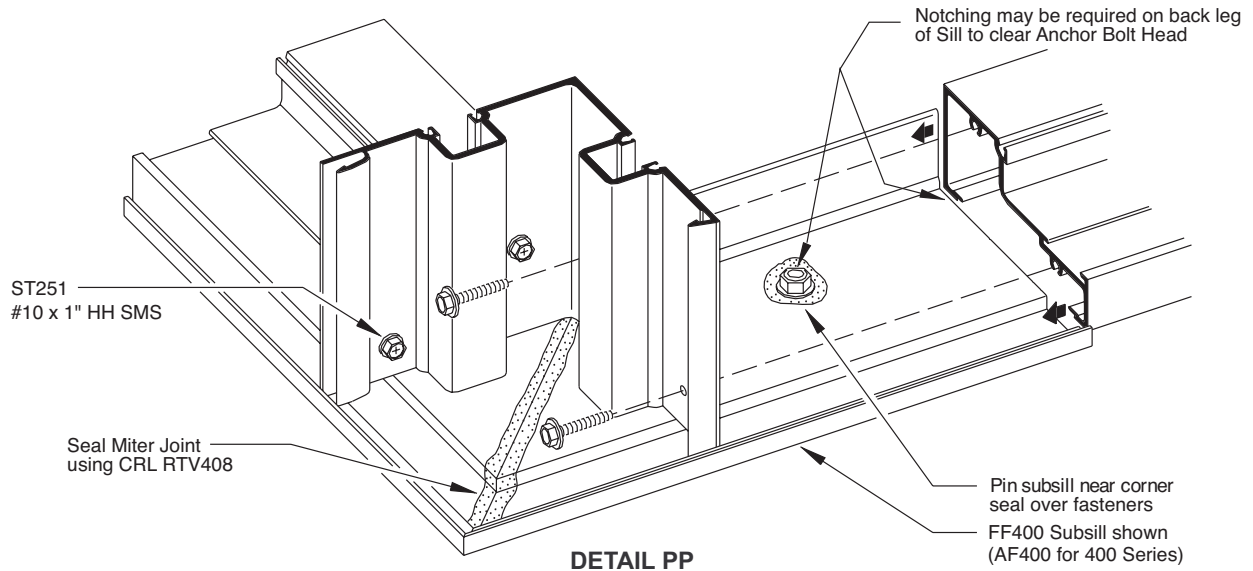

135° INSIDE/OUTSIDE CORNERS

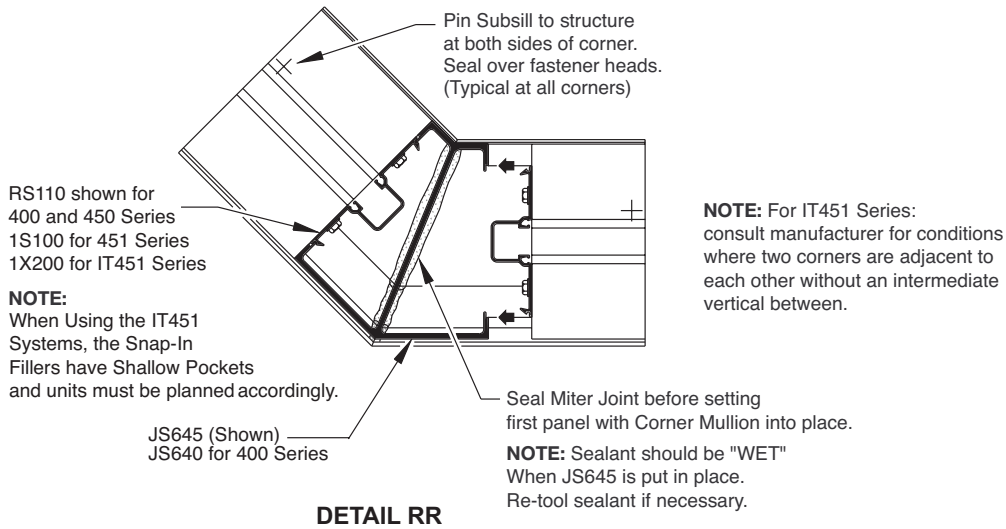

0° - 24° INSIDE/OUTSIDE CORNERS

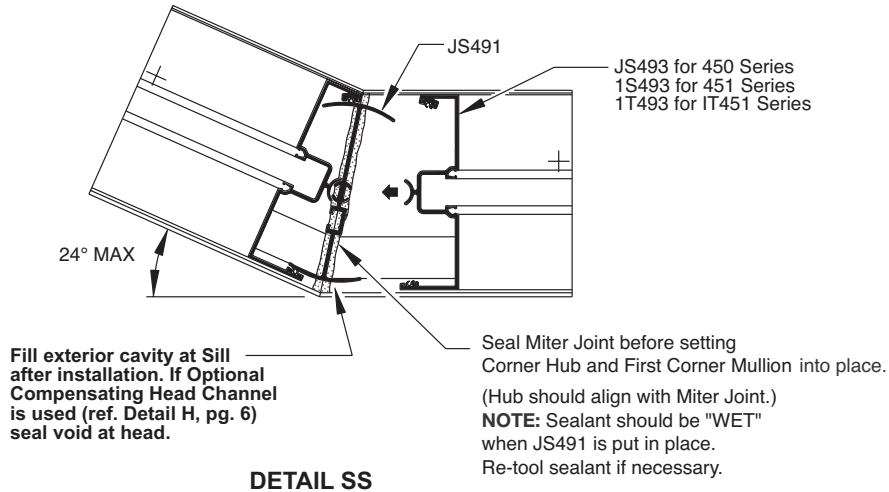

VARIOUS ODD ANGLE CORNERS

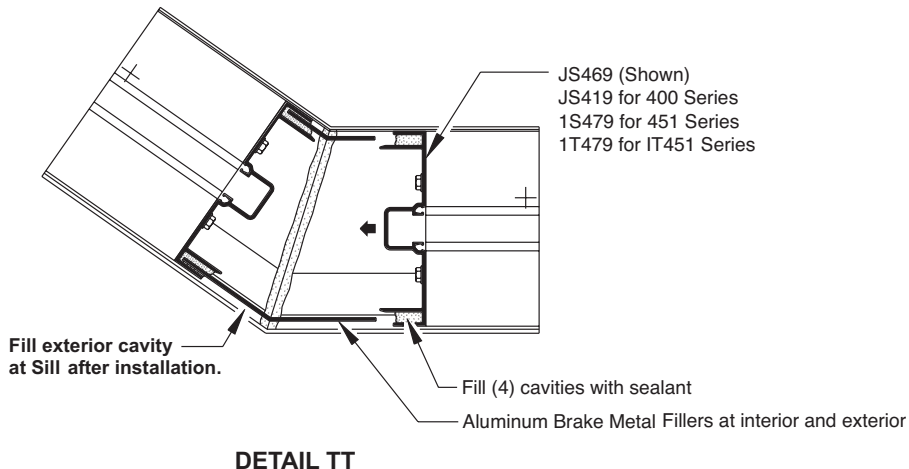

EXPANSION MULLIONS

Expansion Mullions must be used to accommodate thermal movement in long run elevations.

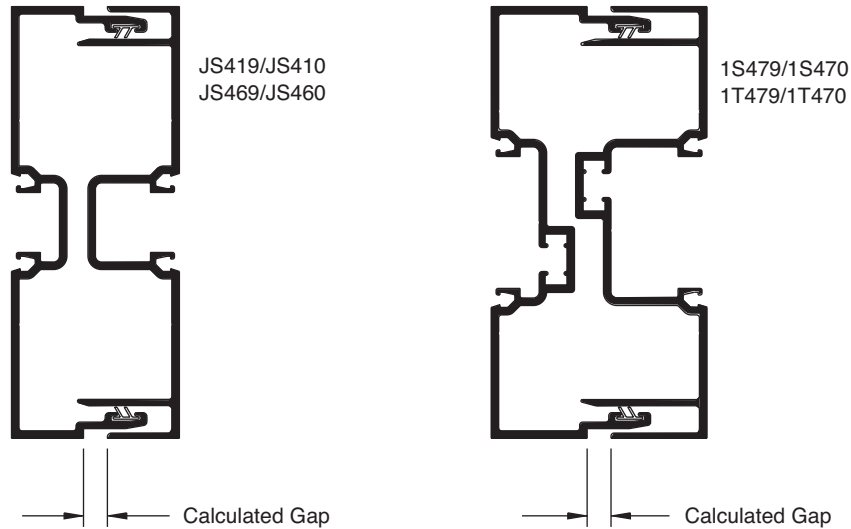

DETAIL UU

Expansion Mullions must be used to accommodate thermal movement in long run elevations. They should be spaced as required by job conditions and project specifications. Two-piece Mullions allow for a 3/8" (9.5) maximum movement. Gap between Half Members should be based on temperature at the time of installation.

EXPANSION JOINT SIZE FORMULA

Linear Expansion for Aluminum, in Inches = Length (") X F° Difference X .0000129
Linear Expansion for Aluminum, in Millimeters = Length (m) X C° Difference X .02322

NOTE: Linear expansion from formula above equals Calculated Gap. See **DETAIL UU**

For Door Frames, See Door Frame Installation Instructions



JOB SITE ESSENTIALS

Helpful Tools and Supplies for Installing CRL U.S. Aluminum Entrances, Storefronts, Windows, and Curtain Wall Systems



CRL 95C Silicone Building Sealant
CAT. NO. 95C



CRL RTV408 Neutral Cure Silicone
CAT. NO. RTV408



CRL33S Acetic Cure Silicone
CAT. NO. 33S



CRL M64 Smooth Texture Modified Polyurethane Construction Sealant
CAT. NO. M64GRY



CRL M66 Grainy Texture Modified Polyurethane Construction Sealant
CAT. NO. M66



CRL12:1 Ratio Strap Frame Caulking Gun
CAT. NO. GA1203



CRL Complete Set of Seven All Stainless Steel Spatulas
CAT. NO. AB958G



CRL B0CBR Series Open Cell Backer Rod



CRL Backer Rod Roller Tool
CAT. NO. SBRR

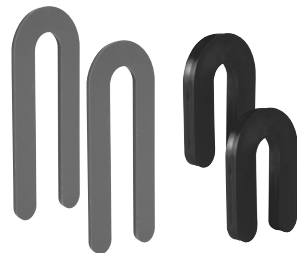

CRL PHS Series Plastic Horseshoe Shims



CRL Glass Cleaner
CAT. NO. 1973



CRL Glass Wipes
CAT. NO. 1550

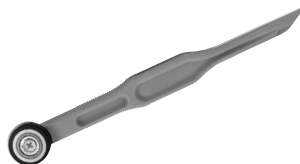

CRL Gasket Roller
CAT. NO. VR10



CRL Running Pliers
CAT. NO. PPG1



CRL Vacuum Cup
CAT. NO. S7950

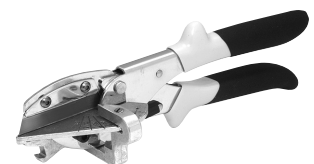

CRL Gasket Cutter
CAT. NO. MC80N

SERIES 400, 450, 451, AND IT451



**CRL Bond Breaker Tape
CAT. NO. 827T2**



**CRL Glass Cutter
CAT. NO. S1050**



**CRL Soft-Face Power Hitter
CAT. NO. ST57532**



**CRL Digital Level Tool
CAT. NO. 406065**



**CRL Tape Measure
CAT. NO. 54125**

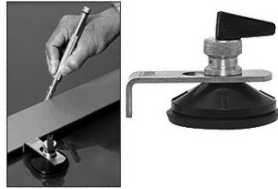

**CRL Glazier's Rule Holder
CAT. NO. RH670**



**CRL Phenolic L-Square
CAT. NO. L48**



**CRL Spring Clamp
CAT. NO. JC3202HT**



**CRL Glass Marking Pencils
CAT. NO. GM44**



**CRL Belt Sander
CAT. NO. LD321**



**CRL Glass Grinding Belts
CAT. NO. CRL3X21120X**



**CRL All Terrain Dolly
CAT. NO. ATD1**



**CRL Gloves
CAT. NO. KF1TL**



**CRL Utility Knife
CAT. NO. K82**



**CRL Utility Knife Blades
CAT. NO. 1992C**



**CRL Cordless Driver/Drill
CAT. NO. LD147**



**CRL Cordless Screwdriver
CAT. NO. LD823**



**CRL Portable Miter Saw 10"
CAT. NO. LS1040**



**CRL Hard Hat
CAT. NO. ES3452**

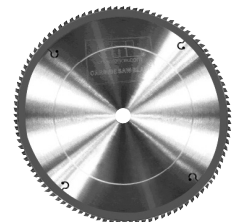

**CRL Cougar Carbide Saw Blade
CAT. NO. CT10X100**